

MANILDRA GROUP - Procedure for inspecting incoming mobile plant

1. MOBILE PLANT EXCAVATOR

<p>Supplier verification & Plant details</p> <p>Plant owner: _____</p> <p>Address: _____</p> <p>City/Suburb: _____</p> <p>Phone: _____</p> <p>Plant make: _____</p> <p>Plant model: _____</p> <p>Serial no.: _____</p> <p>Signature: _____</p> <p>Date: _____</p>	<table style="width: 100%; border-collapse: collapse;"> <tr> <td style="width: 30%; vertical-align: top; padding: 5px;"> <p>ENVIRONMENTAL</p> <p>Clean, free of weeds prior to arrival</p> <p>Verify <input type="checkbox"/> Check <input type="checkbox"/></p> </td> <td style="width: 30%; vertical-align: top; padding: 5px;"> <p>Hydraulics</p> <p>Rams Hoses Connections (check for excessive wear, leaks and creep)</p> <p>Verify <input type="checkbox"/> Check <input type="checkbox"/></p> </td> <td style="width: 30%; vertical-align: top; padding: 5px;"> <p>WARNING DEVICES</p> <p>Horn Amber flashing beacon Reversing alarm</p> <p>Verify <input type="checkbox"/> Check <input type="checkbox"/></p> </td> </tr> <tr> <td style="width: 30%; vertical-align: top; padding: 5px;"> <p>SWL/Crane chart</p> <p>Verify <input type="checkbox"/> Check <input type="checkbox"/></p> </td> <td style="width: 30%; vertical-align: top; padding: 5px;"> <p>Quick hitch</p> <p>Safety pins (If quick hitch is fitted "NO LIFTING POINTS ALLOWED" on back of bucket)</p> <p>Verify <input type="checkbox"/> Check <input type="checkbox"/></p> </td> <td style="width: 30%; vertical-align: top; padding: 5px;"> <p>WARNING SIGNS (in cabin)</p> <p>SEAT BELTS MUST BE WORN</p> <p>DANGER – BEWARE OVERHEAD WIRES & UNDERGROUND SERVICES</p> <p>Verify <input type="checkbox"/> Check <input type="checkbox"/></p> </td> </tr> <tr> <td style="width: 30%; vertical-align: top; padding: 5px;"> <p>Manildra use only</p> <p>NOTE: Sign only when all items have been checked</p> <p>Plant check by: _____</p> <p>Position: _____</p> <p>Date: _____ / ____ / ____</p> </td> <td style="width: 30%; vertical-align: top; padding: 5px;"> <p>TRACKS</p> <p>Trams Hoses Connections (check for excessive wear, leaks and creep)</p> <p>Verify <input type="checkbox"/> Check <input type="checkbox"/></p> </td> <td style="width: 30%; vertical-align: top; padding: 5px;"> <p>CAB</p> <p>Cleanliness Seat condition OK Operator restraint provided Instruments operational & labelled Levers / controls operational Pedals in good condition ROPS to AS 2294 Windows / wipers / washers Rear view mirrors Operator instruction (available on plant) Log Book Fire extinguisher with current tag</p> <p>Verify <input type="checkbox"/> Check <input type="checkbox"/></p> </td> </tr> <tr> <td style="width: 30%; vertical-align: top; padding: 5px;"> <p>EXHAUST</p> <p>Exhaust _____</p> <p>Verify <input type="checkbox"/> Check <input type="checkbox"/></p> </td> <td style="width: 30%; vertical-align: top; padding: 5px;"> <p>TRACKS</p> <p>Tracks complete Idlers adjusted Drivers free from leaks</p> <p>Verify <input type="checkbox"/> Check <input type="checkbox"/></p> </td> <td style="width: 30%; vertical-align: top; padding: 5px;"> <p>EXHAUST</p> <p>Engine guarding _____</p> <p>Verify <input type="checkbox"/> Check <input type="checkbox"/></p> </td> </tr> </table>	<p>ENVIRONMENTAL</p> <p>Clean, free of weeds prior to arrival</p> <p>Verify <input type="checkbox"/> Check <input type="checkbox"/></p>	<p>Hydraulics</p> <p>Rams Hoses Connections (check for excessive wear, leaks and creep)</p> <p>Verify <input type="checkbox"/> Check <input type="checkbox"/></p>	<p>WARNING DEVICES</p> <p>Horn Amber flashing beacon Reversing alarm</p> <p>Verify <input type="checkbox"/> Check <input type="checkbox"/></p>	<p>SWL/Crane chart</p> <p>Verify <input type="checkbox"/> Check <input type="checkbox"/></p>	<p>Quick hitch</p> <p>Safety pins (If quick hitch is fitted "NO LIFTING POINTS ALLOWED" on back of bucket)</p> <p>Verify <input type="checkbox"/> Check <input type="checkbox"/></p>	<p>WARNING SIGNS (in cabin)</p> <p>SEAT BELTS MUST BE WORN</p> <p>DANGER – BEWARE OVERHEAD WIRES & UNDERGROUND SERVICES</p> <p>Verify <input type="checkbox"/> Check <input type="checkbox"/></p>	<p>Manildra use only</p> <p>NOTE: Sign only when all items have been checked</p> <p>Plant check by: _____</p> <p>Position: _____</p> <p>Date: _____ / ____ / ____</p>	<p>TRACKS</p> <p>Trams Hoses Connections (check for excessive wear, leaks and creep)</p> <p>Verify <input type="checkbox"/> Check <input type="checkbox"/></p>	<p>CAB</p> <p>Cleanliness Seat condition OK Operator restraint provided Instruments operational & labelled Levers / controls operational Pedals in good condition ROPS to AS 2294 Windows / wipers / washers Rear view mirrors Operator instruction (available on plant) Log Book Fire extinguisher with current tag</p> <p>Verify <input type="checkbox"/> Check <input type="checkbox"/></p>	<p>EXHAUST</p> <p>Exhaust _____</p> <p>Verify <input type="checkbox"/> Check <input type="checkbox"/></p>	<p>TRACKS</p> <p>Tracks complete Idlers adjusted Drivers free from leaks</p> <p>Verify <input type="checkbox"/> Check <input type="checkbox"/></p>	<p>EXHAUST</p> <p>Engine guarding _____</p> <p>Verify <input type="checkbox"/> Check <input type="checkbox"/></p>
<p>ENVIRONMENTAL</p> <p>Clean, free of weeds prior to arrival</p> <p>Verify <input type="checkbox"/> Check <input type="checkbox"/></p>	<p>Hydraulics</p> <p>Rams Hoses Connections (check for excessive wear, leaks and creep)</p> <p>Verify <input type="checkbox"/> Check <input type="checkbox"/></p>	<p>WARNING DEVICES</p> <p>Horn Amber flashing beacon Reversing alarm</p> <p>Verify <input type="checkbox"/> Check <input type="checkbox"/></p>											
<p>SWL/Crane chart</p> <p>Verify <input type="checkbox"/> Check <input type="checkbox"/></p>	<p>Quick hitch</p> <p>Safety pins (If quick hitch is fitted "NO LIFTING POINTS ALLOWED" on back of bucket)</p> <p>Verify <input type="checkbox"/> Check <input type="checkbox"/></p>	<p>WARNING SIGNS (in cabin)</p> <p>SEAT BELTS MUST BE WORN</p> <p>DANGER – BEWARE OVERHEAD WIRES & UNDERGROUND SERVICES</p> <p>Verify <input type="checkbox"/> Check <input type="checkbox"/></p>											
<p>Manildra use only</p> <p>NOTE: Sign only when all items have been checked</p> <p>Plant check by: _____</p> <p>Position: _____</p> <p>Date: _____ / ____ / ____</p>	<p>TRACKS</p> <p>Trams Hoses Connections (check for excessive wear, leaks and creep)</p> <p>Verify <input type="checkbox"/> Check <input type="checkbox"/></p>	<p>CAB</p> <p>Cleanliness Seat condition OK Operator restraint provided Instruments operational & labelled Levers / controls operational Pedals in good condition ROPS to AS 2294 Windows / wipers / washers Rear view mirrors Operator instruction (available on plant) Log Book Fire extinguisher with current tag</p> <p>Verify <input type="checkbox"/> Check <input type="checkbox"/></p>											
<p>EXHAUST</p> <p>Exhaust _____</p> <p>Verify <input type="checkbox"/> Check <input type="checkbox"/></p>	<p>TRACKS</p> <p>Tracks complete Idlers adjusted Drivers free from leaks</p> <p>Verify <input type="checkbox"/> Check <input type="checkbox"/></p>	<p>EXHAUST</p> <p>Engine guarding _____</p> <p>Verify <input type="checkbox"/> Check <input type="checkbox"/></p>											

Instructions:
Verify Box to be ticked by Owner / Supplier / Operator prior to arrival onsite.
Check Box to be ticked after visual inspection by Manildra

2. MOBILE PLANT ELEVATING WORK PLATFORM

<p>Supplier verification & Plant details</p> <p>Plant owner: _____</p> <p>Address: _____</p> <p>City/Suburb: _____</p> <p>Phone: _____</p> <p>Plant make: _____</p> <p>Plant model: _____</p> <p>Serial no.: _____</p> <p>Signature: _____</p> <p>Date: _____</p> <p>SafeWork Certification – WP</p> <ul style="list-style-type: none"> • Plant to conform to manufacturer’s specifications and Plant Regulations. • Plant operator is to provide daily check sheets to Manildra on a weekly basis. • Where applicable, Personal Protective Equipment must be worn. • Plant Log Book detailing service history in accordance with Manufacturer’s specifications should be written legibly in English. • Contractor must produce proof of competence of operator, e.g., Certificate of Competence, Licence, detailed Log Book 	<div style="display: flex; justify-content: space-between;"> <div style="width: 45%;"> <p>Warning devices</p> <table border="1" style="width: 100%; border-collapse: collapse;"> <tr><td>Verify</td><td>Check</td><td></td></tr> <tr><td></td><td></td><td>Horn</td></tr> <tr><td></td><td></td><td>Amber flashing beacon</td></tr> <tr><td></td><td></td><td>Motion alarms</td></tr> <tr><td></td><td></td><td>Raise & lower alarms</td></tr> <tr><td></td><td></td><td>Out of level alarm</td></tr> </table> </div> <div style="width: 45%;"> <p>Basket</p> <table border="1" style="width: 100%; border-collapse: collapse;"> <tr><td>Verify</td><td>Check</td><td></td></tr> <tr><td></td><td></td><td>Cleanliness</td></tr> <tr><td></td><td></td><td>Operator restraint</td></tr> <tr><td></td><td></td><td>Instruments & labeling</td></tr> <tr><td></td><td></td><td>Levers / controls</td></tr> <tr><td></td><td></td><td>Pedals</td></tr> <tr><td></td><td></td><td>Log book</td></tr> <tr><td></td><td></td><td>Deadman switch</td></tr> <tr><td></td><td></td><td>operating instructions (available on plant)</td></tr> <tr><td>Verify</td><td>Check</td><td></td></tr> <tr><td></td><td></td><td>SWL / Crane Chart</td></tr> <tr><td>Verify</td><td>Check</td><td></td></tr> <tr><td></td><td></td><td>Safety Harness & Lanyard</td></tr> </table> </div> </div> <div style="display: flex; justify-content: space-between; margin-top: 20px;"> <div style="width: 45%;"> <p>Hydraulics</p> <table border="1" style="width: 100%; border-collapse: collapse;"> <tr><td>Verify</td><td>Check</td><td></td></tr> <tr><td></td><td></td><td>Rams</td></tr> <tr><td></td><td></td><td>Hoses</td></tr> <tr><td></td><td></td><td>Connections</td></tr> <tr><td></td><td></td><td>(check for excessive wear, leaks and creep)</td></tr> </table> </div> <div style="width: 45%;"> <p>Warning signs (in cabin)</p> <div style="border: 1px solid black; padding: 5px; text-align: center; margin-bottom: 5px;"> SEAT BELTS MUST BE WORN </div> <div style="border: 1px solid black; padding: 5px; text-align: center;"> DANGER – BEWARE OVERHEAD WIRES & SERVICES </div> </div> </div> <div style="display: flex; justify-content: space-between; margin-top: 20px;"> <div style="width: 45%;"> <p>Hydraulics</p> <table border="1" style="width: 100%; border-collapse: collapse;"> <tr><td>Verify</td><td>Check</td><td></td></tr> <tr><td></td><td></td><td>Pivots</td></tr> <tr><td></td><td></td><td>Connecting Rods</td></tr> <tr><td></td><td></td><td>Safety Pins</td></tr> <tr><td></td><td></td><td>(no excessive wear)</td></tr> </table> </div> <div style="width: 45%;"> <p>Hydraulics</p> <table border="1" style="width: 100%; border-collapse: collapse;"> <tr><td>Verify</td><td>Check</td><td></td></tr> <tr><td></td><td></td><td>Rams</td></tr> <tr><td></td><td></td><td>Hoses</td></tr> <tr><td></td><td></td><td>Connections</td></tr> <tr><td></td><td></td><td>(check for excessive wear, leaks and creep)</td></tr> </table> </div> </div> <div style="display: flex; justify-content: space-between; margin-top: 20px;"> <div style="width: 45%;"> <p>Exhaust</p> <table border="1" style="width: 100%; border-collapse: collapse;"> <tr><td>Verify</td><td>Check</td><td></td></tr> <tr><td></td><td></td><td></td></tr> </table> </div> <div style="width: 45%;"> <p>Hydraulics</p> <table border="1" style="width: 100%; border-collapse: collapse;"> <tr><td>Verify</td><td>Check</td><td></td></tr> <tr><td></td><td></td><td></td></tr> <tr><td></td><td></td><td></td></tr> </table> </div> </div> <div style="display: flex; justify-content: space-between; margin-top: 20px;"> <div style="width: 45%;"> <p>Levers / controls</p> <table border="1" style="width: 100%; border-collapse: collapse;"> <tr><td>Verify</td><td>Check</td><td></td></tr> <tr><td></td><td></td><td></td></tr> </table> </div> <div style="width: 45%;"> <p>Engine guarding</p> <table border="1" style="width: 100%; border-collapse: collapse;"> <tr><td>Verify</td><td>Check</td><td></td></tr> <tr><td></td><td></td><td></td></tr> </table> </div> </div> <div style="display: flex; justify-content: space-between; margin-top: 20px;"> <div style="width: 45%;"> <p>Tyres</p> <table border="1" style="width: 100%; border-collapse: collapse;"> <tr><td>Verify</td><td>Check</td><td></td></tr> <tr><td></td><td></td><td></td></tr> <tr><td></td><td></td><td></td></tr> <tr><td></td><td></td><td></td></tr> <tr><td></td><td></td><td></td></tr> </table> </div> <div style="width: 45%;"> <p>Hydraulics</p> <table border="1" style="width: 100%; border-collapse: collapse;"> <tr><td>Verify</td><td>Check</td><td></td></tr> <tr><td></td><td></td><td></td></tr> <tr><td></td><td></td><td></td></tr> <tr><td></td><td></td><td></td></tr> <tr><td></td><td></td><td></td></tr> </table> </div> </div>	Verify	Check				Horn			Amber flashing beacon			Motion alarms			Raise & lower alarms			Out of level alarm	Verify	Check				Cleanliness			Operator restraint			Instruments & labeling			Levers / controls			Pedals			Log book			Deadman switch			operating instructions (available on plant)	Verify	Check				SWL / Crane Chart	Verify	Check				Safety Harness & Lanyard	Verify	Check				Rams			Hoses			Connections			(check for excessive wear, leaks and creep)	Verify	Check				Pivots			Connecting Rods			Safety Pins			(no excessive wear)	Verify	Check				Rams			Hoses			Connections			(check for excessive wear, leaks and creep)	Verify	Check					Verify	Check								Verify	Check					Verify	Check					Verify	Check														Verify	Check													
Verify	Check																																																																																																																																																															
		Horn																																																																																																																																																														
		Amber flashing beacon																																																																																																																																																														
		Motion alarms																																																																																																																																																														
		Raise & lower alarms																																																																																																																																																														
		Out of level alarm																																																																																																																																																														
Verify	Check																																																																																																																																																															
		Cleanliness																																																																																																																																																														
		Operator restraint																																																																																																																																																														
		Instruments & labeling																																																																																																																																																														
		Levers / controls																																																																																																																																																														
		Pedals																																																																																																																																																														
		Log book																																																																																																																																																														
		Deadman switch																																																																																																																																																														
		operating instructions (available on plant)																																																																																																																																																														
Verify	Check																																																																																																																																																															
		SWL / Crane Chart																																																																																																																																																														
Verify	Check																																																																																																																																																															
		Safety Harness & Lanyard																																																																																																																																																														
Verify	Check																																																																																																																																																															
		Rams																																																																																																																																																														
		Hoses																																																																																																																																																														
		Connections																																																																																																																																																														
		(check for excessive wear, leaks and creep)																																																																																																																																																														
Verify	Check																																																																																																																																																															
		Pivots																																																																																																																																																														
		Connecting Rods																																																																																																																																																														
		Safety Pins																																																																																																																																																														
		(no excessive wear)																																																																																																																																																														
Verify	Check																																																																																																																																																															
		Rams																																																																																																																																																														
		Hoses																																																																																																																																																														
		Connections																																																																																																																																																														
		(check for excessive wear, leaks and creep)																																																																																																																																																														
Verify	Check																																																																																																																																																															
Verify	Check																																																																																																																																																															
Verify	Check																																																																																																																																																															
Verify	Check																																																																																																																																																															
Verify	Check																																																																																																																																																															
Verify	Check																																																																																																																																																															
<p>Manildra use only</p> <p>NOTE: Sign only when all items have been checked</p> <p>Plant check by: _____</p> <p>Position: _____</p> <p>Date: _____ / ____ / ____</p>	<p>Instructions:</p> <p>Verify Box to be ticked by Owner / Supplier / Operator prior to arrival onsite.</p> <p>Check Box to be ticked after visual inspection by Manildra</p>																																																																																																																																																															

3. MOBILE PLANT PAD ROLLER

<p>Supplier verification & Plant details</p> <p>Plant owner: _____</p> <p>Address: _____</p> <p>City/Suburb: _____</p> <p>Phone: _____</p> <p>Plant make: _____</p> <p>Plant model: _____</p> <p>Serial no.: _____</p> <p>Signature: _____</p> <p>Date: _____</p> <p>Statement of operator competence required</p>	<table style="width: 100%; border-collapse: collapse;"> <tr> <td style="width: 30%; vertical-align: top;"> <p>Verify Check Cab</p> <table style="width: 100%; border-collapse: collapse;"> <tr><td style="width: 20px; height: 20px; border: 1px solid black;"></td><td style="width: 20px; height: 20px; border: 1px solid black;"></td><td>Cleanliness</td></tr> <tr><td style="width: 20px; height: 20px; border: 1px solid black;"></td><td style="width: 20px; height: 20px; border: 1px solid black;"></td><td>Seat condition OK</td></tr> <tr><td style="width: 20px; height: 20px; border: 1px solid black;"></td><td style="width: 20px; height: 20px; border: 1px solid black;"></td><td>Operator restraint provided</td></tr> <tr><td style="width: 20px; height: 20px; border: 1px solid black;"></td><td style="width: 20px; height: 20px; border: 1px solid black;"></td><td>Instruments operational & labelled</td></tr> <tr><td style="width: 20px; height: 20px; border: 1px solid black;"></td><td style="width: 20px; height: 20px; border: 1px solid black;"></td><td>Levers / controls operational</td></tr> <tr><td style="width: 20px; height: 20px; border: 1px solid black;"></td><td style="width: 20px; height: 20px; border: 1px solid black;"></td><td>Pedals in good condition</td></tr> <tr><td style="width: 20px; height: 20px; border: 1px solid black;"></td><td style="width: 20px; height: 20px; border: 1px solid black;"></td><td>ROPS to AS 2294</td></tr> <tr><td style="width: 20px; height: 20px; border: 1px solid black;"></td><td style="width: 20px; height: 20px; border: 1px solid black;"></td><td>Windows / wipers / washers</td></tr> <tr><td style="width: 20px; height: 20px; border: 1px solid black;"></td><td style="width: 20px; height: 20px; border: 1px solid black;"></td><td>Rear view mirrors</td></tr> <tr><td style="width: 20px; height: 20px; border: 1px solid black;"></td><td style="width: 20px; height: 20px; border: 1px solid black;"></td><td>Operator instruction (Available on plant)</td></tr> </table> </td> <td style="width: 40%; vertical-align: top;"> <p>Verify Check Warning devices</p> <table style="width: 100%; border-collapse: collapse;"> <tr><td style="width: 20px; height: 20px; border: 1px solid black;"></td><td style="width: 20px; height: 20px; border: 1px solid black;"></td><td>Horn</td></tr> <tr><td style="width: 20px; height: 20px; border: 1px solid black;"></td><td style="width: 20px; height: 20px; border: 1px solid black;"></td><td>Amber flashing beacon (all)</td></tr> <tr><td style="width: 20px; height: 20px; border: 1px solid black;"></td><td style="width: 20px; height: 20px; border: 1px solid black;"></td><td>Reversing alarm</td></tr> </table> <p>Verify Check Warning signs (in cabin)</p> <div style="border: 1px solid black; padding: 5px; margin-bottom: 5px;"> <p>SEAT BELTS MUST BE WORN</p> </div> <div style="border: 1px solid black; padding: 5px;"> <p>DANGER – SAFE WORKING LIMITS ON BATTERS</p> <p>Ratio 4 to 1</p> <p>example only. As per manufacturer's specification</p> </div> </td> </tr> <tr> <td style="vertical-align: top; padding: 5px;"> <ul style="list-style-type: none"> Plant to conform to manufacturer's specifications and Plant Regulations. Plant operator is to provide daily check sheets to Manildra on a weekly basis Where applicable, Personal Protective Equipment must be worn. Plant Log Book detailing service history in accordance with Manufacturer's specifications should be written legibly in English. Contractor must produce proof of competence of operator, e.g., Certificate of Competence, Licence, detailed Log Book </td> <td style="vertical-align: top; padding: 5px;"> <p>Verify Check Exhaust</p> <table style="width: 100%; border-collapse: collapse;"> <tr><td style="width: 20px; height: 20px; border: 1px solid black;"></td><td style="width: 20px; height: 20px; border: 1px solid black;"></td><td>Exhaust</td></tr> </table> <p>Verify Check Engine guarding</p> <table style="width: 100%; border-collapse: collapse;"> <tr><td style="width: 20px; height: 20px; border: 1px solid black;"></td><td style="width: 20px; height: 20px; border: 1px solid black;"></td><td>Engine guarding</td></tr> </table> <p>Verify Check Tyres</p> <table style="width: 100%; border-collapse: collapse;"> <tr><td style="width: 20px; height: 20px; border: 1px solid black;"></td><td style="width: 20px; height: 20px; border: 1px solid black;"></td><td>Tyres</td></tr> <tr><td style="width: 20px; height: 20px; border: 1px solid black;"></td><td style="width: 20px; height: 20px; border: 1px solid black;"></td><td>Wheels</td></tr> <tr><td style="width: 20px; height: 20px; border: 1px solid black;"></td><td style="width: 20px; height: 20px; border: 1px solid black;"></td><td>Brakes</td></tr> <tr><td style="width: 20px; height: 20px; border: 1px solid black;"></td><td style="width: 20px; height: 20px; border: 1px solid black;"></td><td>Park brake</td></tr> </table> <p>Verify Check Crush point hazard sign displayed both sides</p> <table style="width: 100%; border-collapse: collapse;"> <tr><td style="width: 20px; height: 20px; border: 1px solid black;"></td><td style="width: 20px; height: 20px; border: 1px solid black;"></td><td>Crush point hazard sign displayed both sides</td></tr> </table> </td> <td style="vertical-align: top; padding: 5px;"> <p>Verify Check Handrails Steps</p> <table style="width: 100%; border-collapse: collapse;"> <tr><td style="width: 20px; height: 20px; border: 1px solid black;"></td><td style="width: 20px; height: 20px; border: 1px solid black;"></td><td>Handrails</td></tr> <tr><td style="width: 20px; height: 20px; border: 1px solid black;"></td><td style="width: 20px; height: 20px; border: 1px solid black;"></td><td>Steps</td></tr> </table> <p>Verify Check Hydraulics</p> <table style="width: 100%; border-collapse: collapse;"> <tr><td style="width: 20px; height: 20px; border: 1px solid black;"></td><td style="width: 20px; height: 20px; border: 1px solid black;"></td><td>Rams</td></tr> <tr><td style="width: 20px; height: 20px; border: 1px solid black;"></td><td style="width: 20px; height: 20px; border: 1px solid black;"></td><td>Hoses</td></tr> <tr><td style="width: 20px; height: 20px; border: 1px solid black;"></td><td style="width: 20px; height: 20px; border: 1px solid black;"></td><td>Connections (check for excessive wear, leaks and creep)</td></tr> </table> </td> <td style="vertical-align: top; padding: 5px;"> <p>Verify Check Locating lock for Low/Neutral/Lower range padlock provided</p> <table style="width: 100%; border-collapse: collapse;"> <tr><td style="width: 20px; height: 20px; border: 1px solid black;"></td><td style="width: 20px; height: 20px; border: 1px solid black;"></td><td>Locating lock for Low/Neutral/Lower range padlock provided</td></tr> </table> <p>Verify Check Warning sign – hasp must be locked in position before operating</p> <p>Verify Check Rubber mounts (drum)</p> <table style="width: 100%; border-collapse: collapse;"> <tr><td style="width: 20px; height: 20px; border: 1px solid black;"></td><td style="width: 20px; height: 20px; border: 1px solid black;"></td><td>Rubber mounts (drum)</td></tr> </table> <p>Verify Check Drum cleaning rakes</p> <table style="width: 100%; border-collapse: collapse;"> <tr><td style="width: 20px; height: 20px; border: 1px solid black;"></td><td style="width: 20px; height: 20px; border: 1px solid black;"></td><td>Drum cleaning rakes</td></tr> </table> </td> </tr> <tr> <td style="vertical-align: top; padding: 5px;"> <p>Manildra use only</p> <p>NOTE: Sign only when all items have been checked</p> <p>Plant check by: _____</p> <p>Position: _____</p> <p>Date: _____ / ____ / ____</p> </td> <td colspan="3" style="vertical-align: top; padding: 5px;"> <p>Instructions:</p> <p>Verify Box to be ticked by Owner / Supplier / Operator prior to arrival onsite. Check Box to be ticked after visual inspection by Manildra</p> </td> </tr> </table>	<p>Verify Check Cab</p> <table style="width: 100%; border-collapse: collapse;"> <tr><td style="width: 20px; height: 20px; border: 1px solid black;"></td><td style="width: 20px; height: 20px; border: 1px solid black;"></td><td>Cleanliness</td></tr> <tr><td style="width: 20px; height: 20px; border: 1px solid black;"></td><td style="width: 20px; height: 20px; border: 1px solid black;"></td><td>Seat condition OK</td></tr> <tr><td style="width: 20px; height: 20px; border: 1px solid black;"></td><td style="width: 20px; height: 20px; border: 1px solid black;"></td><td>Operator restraint provided</td></tr> <tr><td style="width: 20px; height: 20px; border: 1px solid black;"></td><td style="width: 20px; height: 20px; border: 1px solid black;"></td><td>Instruments operational & labelled</td></tr> <tr><td style="width: 20px; height: 20px; border: 1px solid black;"></td><td style="width: 20px; height: 20px; border: 1px solid black;"></td><td>Levers / controls operational</td></tr> <tr><td style="width: 20px; height: 20px; border: 1px solid black;"></td><td style="width: 20px; height: 20px; border: 1px solid black;"></td><td>Pedals in good condition</td></tr> <tr><td style="width: 20px; height: 20px; border: 1px solid black;"></td><td style="width: 20px; height: 20px; border: 1px solid black;"></td><td>ROPS to AS 2294</td></tr> <tr><td style="width: 20px; height: 20px; border: 1px solid black;"></td><td style="width: 20px; height: 20px; border: 1px solid black;"></td><td>Windows / wipers / washers</td></tr> <tr><td style="width: 20px; height: 20px; border: 1px solid black;"></td><td style="width: 20px; height: 20px; border: 1px solid black;"></td><td>Rear view mirrors</td></tr> <tr><td style="width: 20px; height: 20px; border: 1px solid black;"></td><td style="width: 20px; height: 20px; border: 1px solid black;"></td><td>Operator instruction (Available on plant)</td></tr> </table>			Cleanliness			Seat condition OK			Operator restraint provided			Instruments operational & labelled			Levers / controls operational			Pedals in good condition			ROPS to AS 2294			Windows / wipers / washers			Rear view mirrors			Operator instruction (Available on plant)	<p>Verify Check Warning devices</p> <table style="width: 100%; border-collapse: collapse;"> <tr><td style="width: 20px; height: 20px; border: 1px solid black;"></td><td style="width: 20px; height: 20px; border: 1px solid black;"></td><td>Horn</td></tr> <tr><td style="width: 20px; height: 20px; border: 1px solid black;"></td><td style="width: 20px; height: 20px; border: 1px solid black;"></td><td>Amber flashing beacon (all)</td></tr> <tr><td style="width: 20px; height: 20px; border: 1px solid black;"></td><td style="width: 20px; height: 20px; border: 1px solid black;"></td><td>Reversing alarm</td></tr> </table> <p>Verify Check Warning signs (in cabin)</p> <div style="border: 1px solid black; padding: 5px; margin-bottom: 5px;"> <p>SEAT BELTS MUST BE WORN</p> </div> <div style="border: 1px solid black; padding: 5px;"> <p>DANGER – SAFE WORKING LIMITS ON BATTERS</p> <p>Ratio 4 to 1</p> <p>example only. As per manufacturer's specification</p> </div>			Horn			Amber flashing beacon (all)			Reversing alarm	<ul style="list-style-type: none"> Plant to conform to manufacturer's specifications and Plant Regulations. Plant operator is to provide daily check sheets to Manildra on a weekly basis Where applicable, Personal Protective Equipment must be worn. Plant Log Book detailing service history in accordance with Manufacturer's specifications should be written legibly in English. Contractor must produce proof of competence of operator, e.g., Certificate of Competence, Licence, detailed Log Book 	<p>Verify Check Exhaust</p> <table style="width: 100%; border-collapse: collapse;"> <tr><td style="width: 20px; height: 20px; border: 1px solid black;"></td><td style="width: 20px; height: 20px; border: 1px solid black;"></td><td>Exhaust</td></tr> </table> <p>Verify Check Engine guarding</p> <table style="width: 100%; border-collapse: collapse;"> <tr><td style="width: 20px; height: 20px; border: 1px solid black;"></td><td style="width: 20px; height: 20px; border: 1px solid black;"></td><td>Engine guarding</td></tr> </table> <p>Verify Check Tyres</p> <table style="width: 100%; border-collapse: collapse;"> <tr><td style="width: 20px; height: 20px; border: 1px solid black;"></td><td style="width: 20px; height: 20px; border: 1px solid black;"></td><td>Tyres</td></tr> <tr><td style="width: 20px; height: 20px; border: 1px solid black;"></td><td style="width: 20px; height: 20px; border: 1px solid black;"></td><td>Wheels</td></tr> <tr><td style="width: 20px; height: 20px; border: 1px solid black;"></td><td style="width: 20px; height: 20px; border: 1px solid black;"></td><td>Brakes</td></tr> <tr><td style="width: 20px; height: 20px; border: 1px solid black;"></td><td style="width: 20px; height: 20px; border: 1px solid black;"></td><td>Park brake</td></tr> </table> <p>Verify Check Crush point hazard sign displayed both sides</p> <table style="width: 100%; border-collapse: collapse;"> <tr><td style="width: 20px; height: 20px; border: 1px solid black;"></td><td style="width: 20px; height: 20px; border: 1px solid black;"></td><td>Crush point hazard sign displayed both sides</td></tr> </table>			Exhaust			Engine guarding			Tyres			Wheels			Brakes			Park brake			Crush point hazard sign displayed both sides	<p>Verify Check Handrails Steps</p> <table style="width: 100%; border-collapse: collapse;"> <tr><td style="width: 20px; height: 20px; border: 1px solid black;"></td><td style="width: 20px; height: 20px; border: 1px solid black;"></td><td>Handrails</td></tr> <tr><td style="width: 20px; height: 20px; border: 1px solid black;"></td><td style="width: 20px; height: 20px; border: 1px solid black;"></td><td>Steps</td></tr> </table> <p>Verify Check Hydraulics</p> <table style="width: 100%; border-collapse: collapse;"> <tr><td style="width: 20px; height: 20px; border: 1px solid black;"></td><td style="width: 20px; height: 20px; border: 1px solid black;"></td><td>Rams</td></tr> <tr><td style="width: 20px; height: 20px; border: 1px solid black;"></td><td style="width: 20px; height: 20px; border: 1px solid black;"></td><td>Hoses</td></tr> <tr><td style="width: 20px; height: 20px; border: 1px solid black;"></td><td style="width: 20px; height: 20px; border: 1px solid black;"></td><td>Connections (check for excessive wear, leaks and creep)</td></tr> </table>			Handrails			Steps			Rams			Hoses			Connections (check for excessive wear, leaks and creep)	<p>Verify Check Locating lock for Low/Neutral/Lower range padlock provided</p> <table style="width: 100%; border-collapse: collapse;"> <tr><td style="width: 20px; height: 20px; border: 1px solid black;"></td><td style="width: 20px; height: 20px; border: 1px solid black;"></td><td>Locating lock for Low/Neutral/Lower range padlock provided</td></tr> </table> <p>Verify Check Warning sign – hasp must be locked in position before operating</p> <p>Verify Check Rubber mounts (drum)</p> <table style="width: 100%; border-collapse: collapse;"> <tr><td style="width: 20px; height: 20px; border: 1px solid black;"></td><td style="width: 20px; height: 20px; border: 1px solid black;"></td><td>Rubber mounts (drum)</td></tr> </table> <p>Verify Check Drum cleaning rakes</p> <table style="width: 100%; border-collapse: collapse;"> <tr><td style="width: 20px; height: 20px; border: 1px solid black;"></td><td style="width: 20px; height: 20px; border: 1px solid black;"></td><td>Drum cleaning rakes</td></tr> </table>			Locating lock for Low/Neutral/Lower range padlock provided			Rubber mounts (drum)			Drum cleaning rakes	<p>Manildra use only</p> <p>NOTE: Sign only when all items have been checked</p> <p>Plant check by: _____</p> <p>Position: _____</p> <p>Date: _____ / ____ / ____</p>	<p>Instructions:</p> <p>Verify Box to be ticked by Owner / Supplier / Operator prior to arrival onsite. Check Box to be ticked after visual inspection by Manildra</p>		
<p>Verify Check Cab</p> <table style="width: 100%; border-collapse: collapse;"> <tr><td style="width: 20px; height: 20px; border: 1px solid black;"></td><td style="width: 20px; height: 20px; border: 1px solid black;"></td><td>Cleanliness</td></tr> <tr><td style="width: 20px; height: 20px; border: 1px solid black;"></td><td style="width: 20px; height: 20px; border: 1px solid black;"></td><td>Seat condition OK</td></tr> <tr><td style="width: 20px; height: 20px; border: 1px solid black;"></td><td style="width: 20px; height: 20px; border: 1px solid black;"></td><td>Operator restraint provided</td></tr> <tr><td style="width: 20px; height: 20px; border: 1px solid black;"></td><td style="width: 20px; height: 20px; border: 1px solid black;"></td><td>Instruments operational & labelled</td></tr> <tr><td style="width: 20px; height: 20px; border: 1px solid black;"></td><td style="width: 20px; height: 20px; border: 1px solid black;"></td><td>Levers / controls operational</td></tr> <tr><td style="width: 20px; height: 20px; border: 1px solid black;"></td><td style="width: 20px; height: 20px; border: 1px solid black;"></td><td>Pedals in good condition</td></tr> <tr><td style="width: 20px; height: 20px; border: 1px solid black;"></td><td style="width: 20px; height: 20px; border: 1px solid black;"></td><td>ROPS to AS 2294</td></tr> <tr><td style="width: 20px; height: 20px; border: 1px solid black;"></td><td style="width: 20px; height: 20px; border: 1px solid black;"></td><td>Windows / wipers / washers</td></tr> <tr><td style="width: 20px; height: 20px; border: 1px solid black;"></td><td style="width: 20px; height: 20px; border: 1px solid black;"></td><td>Rear view mirrors</td></tr> <tr><td style="width: 20px; height: 20px; border: 1px solid black;"></td><td style="width: 20px; height: 20px; border: 1px solid black;"></td><td>Operator instruction (Available on plant)</td></tr> </table>			Cleanliness			Seat condition OK			Operator restraint provided			Instruments operational & labelled			Levers / controls operational			Pedals in good condition			ROPS to AS 2294			Windows / wipers / washers			Rear view mirrors			Operator instruction (Available on plant)	<p>Verify Check Warning devices</p> <table style="width: 100%; border-collapse: collapse;"> <tr><td style="width: 20px; height: 20px; border: 1px solid black;"></td><td style="width: 20px; height: 20px; border: 1px solid black;"></td><td>Horn</td></tr> <tr><td style="width: 20px; height: 20px; border: 1px solid black;"></td><td style="width: 20px; height: 20px; border: 1px solid black;"></td><td>Amber flashing beacon (all)</td></tr> <tr><td style="width: 20px; height: 20px; border: 1px solid black;"></td><td style="width: 20px; height: 20px; border: 1px solid black;"></td><td>Reversing alarm</td></tr> </table> <p>Verify Check Warning signs (in cabin)</p> <div style="border: 1px solid black; padding: 5px; margin-bottom: 5px;"> <p>SEAT BELTS MUST BE WORN</p> </div> <div style="border: 1px solid black; padding: 5px;"> <p>DANGER – SAFE WORKING LIMITS ON BATTERS</p> <p>Ratio 4 to 1</p> <p>example only. As per manufacturer's specification</p> </div>			Horn			Amber flashing beacon (all)			Reversing alarm																																																							
		Cleanliness																																																																																													
		Seat condition OK																																																																																													
		Operator restraint provided																																																																																													
		Instruments operational & labelled																																																																																													
		Levers / controls operational																																																																																													
		Pedals in good condition																																																																																													
		ROPS to AS 2294																																																																																													
		Windows / wipers / washers																																																																																													
		Rear view mirrors																																																																																													
		Operator instruction (Available on plant)																																																																																													
		Horn																																																																																													
		Amber flashing beacon (all)																																																																																													
		Reversing alarm																																																																																													
<ul style="list-style-type: none"> Plant to conform to manufacturer's specifications and Plant Regulations. Plant operator is to provide daily check sheets to Manildra on a weekly basis Where applicable, Personal Protective Equipment must be worn. Plant Log Book detailing service history in accordance with Manufacturer's specifications should be written legibly in English. Contractor must produce proof of competence of operator, e.g., Certificate of Competence, Licence, detailed Log Book 	<p>Verify Check Exhaust</p> <table style="width: 100%; border-collapse: collapse;"> <tr><td style="width: 20px; height: 20px; border: 1px solid black;"></td><td style="width: 20px; height: 20px; border: 1px solid black;"></td><td>Exhaust</td></tr> </table> <p>Verify Check Engine guarding</p> <table style="width: 100%; border-collapse: collapse;"> <tr><td style="width: 20px; height: 20px; border: 1px solid black;"></td><td style="width: 20px; height: 20px; border: 1px solid black;"></td><td>Engine guarding</td></tr> </table> <p>Verify Check Tyres</p> <table style="width: 100%; border-collapse: collapse;"> <tr><td style="width: 20px; height: 20px; border: 1px solid black;"></td><td style="width: 20px; height: 20px; border: 1px solid black;"></td><td>Tyres</td></tr> <tr><td style="width: 20px; height: 20px; border: 1px solid black;"></td><td style="width: 20px; height: 20px; border: 1px solid black;"></td><td>Wheels</td></tr> <tr><td style="width: 20px; height: 20px; border: 1px solid black;"></td><td style="width: 20px; height: 20px; border: 1px solid black;"></td><td>Brakes</td></tr> <tr><td style="width: 20px; height: 20px; border: 1px solid black;"></td><td style="width: 20px; height: 20px; border: 1px solid black;"></td><td>Park brake</td></tr> </table> <p>Verify Check Crush point hazard sign displayed both sides</p> <table style="width: 100%; border-collapse: collapse;"> <tr><td style="width: 20px; height: 20px; border: 1px solid black;"></td><td style="width: 20px; height: 20px; border: 1px solid black;"></td><td>Crush point hazard sign displayed both sides</td></tr> </table>			Exhaust			Engine guarding			Tyres			Wheels			Brakes			Park brake			Crush point hazard sign displayed both sides	<p>Verify Check Handrails Steps</p> <table style="width: 100%; border-collapse: collapse;"> <tr><td style="width: 20px; height: 20px; border: 1px solid black;"></td><td style="width: 20px; height: 20px; border: 1px solid black;"></td><td>Handrails</td></tr> <tr><td style="width: 20px; height: 20px; border: 1px solid black;"></td><td style="width: 20px; height: 20px; border: 1px solid black;"></td><td>Steps</td></tr> </table> <p>Verify Check Hydraulics</p> <table style="width: 100%; border-collapse: collapse;"> <tr><td style="width: 20px; height: 20px; border: 1px solid black;"></td><td style="width: 20px; height: 20px; border: 1px solid black;"></td><td>Rams</td></tr> <tr><td style="width: 20px; height: 20px; border: 1px solid black;"></td><td style="width: 20px; height: 20px; border: 1px solid black;"></td><td>Hoses</td></tr> <tr><td style="width: 20px; height: 20px; border: 1px solid black;"></td><td style="width: 20px; height: 20px; border: 1px solid black;"></td><td>Connections (check for excessive wear, leaks and creep)</td></tr> </table>			Handrails			Steps			Rams			Hoses			Connections (check for excessive wear, leaks and creep)	<p>Verify Check Locating lock for Low/Neutral/Lower range padlock provided</p> <table style="width: 100%; border-collapse: collapse;"> <tr><td style="width: 20px; height: 20px; border: 1px solid black;"></td><td style="width: 20px; height: 20px; border: 1px solid black;"></td><td>Locating lock for Low/Neutral/Lower range padlock provided</td></tr> </table> <p>Verify Check Warning sign – hasp must be locked in position before operating</p> <p>Verify Check Rubber mounts (drum)</p> <table style="width: 100%; border-collapse: collapse;"> <tr><td style="width: 20px; height: 20px; border: 1px solid black;"></td><td style="width: 20px; height: 20px; border: 1px solid black;"></td><td>Rubber mounts (drum)</td></tr> </table> <p>Verify Check Drum cleaning rakes</p> <table style="width: 100%; border-collapse: collapse;"> <tr><td style="width: 20px; height: 20px; border: 1px solid black;"></td><td style="width: 20px; height: 20px; border: 1px solid black;"></td><td>Drum cleaning rakes</td></tr> </table>			Locating lock for Low/Neutral/Lower range padlock provided			Rubber mounts (drum)			Drum cleaning rakes																																															
		Exhaust																																																																																													
		Engine guarding																																																																																													
		Tyres																																																																																													
		Wheels																																																																																													
		Brakes																																																																																													
		Park brake																																																																																													
		Crush point hazard sign displayed both sides																																																																																													
		Handrails																																																																																													
		Steps																																																																																													
		Rams																																																																																													
		Hoses																																																																																													
		Connections (check for excessive wear, leaks and creep)																																																																																													
		Locating lock for Low/Neutral/Lower range padlock provided																																																																																													
		Rubber mounts (drum)																																																																																													
		Drum cleaning rakes																																																																																													
<p>Manildra use only</p> <p>NOTE: Sign only when all items have been checked</p> <p>Plant check by: _____</p> <p>Position: _____</p> <p>Date: _____ / ____ / ____</p>	<p>Instructions:</p> <p>Verify Box to be ticked by Owner / Supplier / Operator prior to arrival onsite. Check Box to be ticked after visual inspection by Manildra</p>																																																																																														

4. MOBILE PLANT DOZER

<p>Supplier verification & Plant details</p> <p>Plant owner: _____</p> <p>Address: _____</p> <p>City/Suburb: _____</p> <p>Phone: _____</p> <p>Plant make: _____</p> <p>Plant model: _____</p> <p>Serial no.: _____</p> <p>Signature: _____</p> <p>Date: _____</p>	<table style="width: 100%; border-collapse: collapse;"> <tr> <td style="width: 30%; vertical-align: top;"> <p>Cab</p> <table style="width: 100%; border-collapse: collapse;"> <tr><td style="text-align: center;">Verify</td><td style="text-align: center;">Check</td><td></td></tr> <tr><td style="text-align: center;">Verify</td><td style="text-align: center;">Check</td><td>Cleanliness</td></tr> <tr><td style="text-align: center;">Verify</td><td style="text-align: center;">Check</td><td>Seat condition OK</td></tr> <tr><td style="text-align: center;">Verify</td><td style="text-align: center;">Check</td><td>Operator restraint provided</td></tr> <tr><td style="text-align: center;">Verify</td><td style="text-align: center;">Check</td><td>Instruments operational & labelled.</td></tr> <tr><td style="text-align: center;">Verify</td><td style="text-align: center;">Check</td><td>Levers / controls operational</td></tr> <tr><td style="text-align: center;">Verify</td><td style="text-align: center;">Check</td><td>Pedals in good condition</td></tr> <tr><td style="text-align: center;">Verify</td><td style="text-align: center;">Check</td><td>ROPS to AS 2294</td></tr> <tr><td style="text-align: center;">Verify</td><td style="text-align: center;">Check</td><td>Windows / wipers / washers</td></tr> <tr><td style="text-align: center;">Verify</td><td style="text-align: center;">Check</td><td>Rear view mirrors</td></tr> <tr><td style="text-align: center;">Verify</td><td style="text-align: center;">Check</td><td>Operator instruction (Available on plant)</td></tr> </table> </td> <td style="width: 35%; vertical-align: top;"> <p>Warning devices</p> <table style="width: 100%; border-collapse: collapse;"> <tr><td style="text-align: center;">Verify</td><td style="text-align: center;">Check</td><td></td></tr> <tr><td style="text-align: center;">Verify</td><td style="text-align: center;">Check</td><td>Horn</td></tr> <tr><td style="text-align: center;">Verify</td><td style="text-align: center;">Check</td><td>Amber flashing beacon < 12T</td></tr> <tr><td style="text-align: center;">Verify</td><td style="text-align: center;">Check</td><td>Reversing alarm</td></tr> </table> <p>Warning signs (in cabin)</p> <table style="width: 100%; border-collapse: collapse;"> <tr><td style="text-align: center;">Verify</td><td style="text-align: center;">Check</td><td></td></tr> <tr><td style="text-align: center;">Verify</td><td style="text-align: center;">Check</td><td></td></tr> </table> <div style="border: 1px solid black; padding: 5px; text-align: center; margin: 5px 0;">SEAT BELTS MUST BE WORN</div> <div style="border: 1px solid black; padding: 5px; text-align: center; margin: 5px 0;">DANGER – BEWARE OVERHEAD WIRES & UNDERGROUND SERVICES</div> </td> <td style="width: 35%; vertical-align: top;"> <table style="width: 100%; border-collapse: collapse;"> <tr><td style="text-align: center;">Verify</td><td style="text-align: center;">Check</td><td></td></tr> <tr><td style="text-align: center;">Verify</td><td style="text-align: center;">Check</td><td>Rams</td></tr> <tr><td style="text-align: center;">Verify</td><td style="text-align: center;">Check</td><td>Hoses</td></tr> <tr><td style="text-align: center;">Verify</td><td style="text-align: center;">Check</td><td>Connections (check for excessive wear, leaks and creep)</td></tr> </table> </td> </tr> <tr> <td colspan="2" style="vertical-align: top; padding: 5px;"> <ul style="list-style-type: none"> Plant to conform to manufacturer's specifications and Plant Regulations. Plant operator is to provide daily check sheets to Manildra on a weekly basis. Where applicable, Personal Protective Equipment must be worn. Plant Log Book detailing service history in accordance with Manufacturer's specifications should be written legibly in English. Contractor must produce proof of competence of operator, e.g., Certificate of Competence, Licence, detailed Log Book </td> </tr> <tr> <td style="vertical-align: top; padding: 5px;"> <p>Manildra use only</p> <p>NOTE: Sign only when all items have been checked</p> <p>Plant check by: _____</p> <p>Position: _____</p> <p>Date: _____ / ____ / ____</p> </td> <td style="vertical-align: top; padding: 5px;"> <table style="width: 100%; border-collapse: collapse;"> <tr> <td style="width: 30%; vertical-align: top;"> <p>Tracks</p> <table style="width: 100%; border-collapse: collapse;"> <tr><td style="text-align: center;">Verify</td><td style="text-align: center;">Check</td><td></td></tr> <tr><td style="text-align: center;">Verify</td><td style="text-align: center;">Check</td><td>Pivots</td></tr> <tr><td style="text-align: center;">Verify</td><td style="text-align: center;">Check</td><td>Pins</td></tr> <tr><td style="text-align: center;">Verify</td><td style="text-align: center;">Check</td><td>Connections</td></tr> <tr><td style="text-align: center;">Verify</td><td style="text-align: center;">Check</td><td>Safety pins</td></tr> </table> </td> <td style="width: 35%; vertical-align: top;"> <table style="width: 100%; border-collapse: collapse;"> <tr><td style="text-align: center;">Verify</td><td style="text-align: center;">Check</td><td></td></tr> <tr><td style="text-align: center;">Verify</td><td style="text-align: center;">Check</td><td>Tracks complete</td></tr> <tr><td style="text-align: center;">Verify</td><td style="text-align: center;">Check</td><td>Idlers adjusted</td></tr> <tr><td style="text-align: center;">Verify</td><td style="text-align: center;">Check</td><td>Drivers free from leaks</td></tr> </table> </td> <td style="width: 35%; vertical-align: top;"> <table style="width: 100%; border-collapse: collapse;"> <tr><td style="text-align: center;">Verify</td><td style="text-align: center;">Check</td><td></td></tr> <tr><td style="text-align: center;">Verify</td><td style="text-align: center;">Check</td><td>Handrails</td></tr> <tr><td style="text-align: center;">Verify</td><td style="text-align: center;">Check</td><td>Steps</td></tr> </table> </td> </tr> </table> <div style="text-align: center; margin-top: 20px;"> </div> <p style="font-size: small; margin-top: 10px;">Instructions: Verify Box to be ticked by Owner / Supplier / Operator prior to arrival onsite. Check Box to be ticked after visual inspection by Manildra</p> </td> </tr> </table>	<p>Cab</p> <table style="width: 100%; border-collapse: collapse;"> <tr><td style="text-align: center;">Verify</td><td style="text-align: center;">Check</td><td></td></tr> <tr><td style="text-align: center;">Verify</td><td style="text-align: center;">Check</td><td>Cleanliness</td></tr> <tr><td style="text-align: center;">Verify</td><td style="text-align: center;">Check</td><td>Seat condition OK</td></tr> <tr><td style="text-align: center;">Verify</td><td style="text-align: center;">Check</td><td>Operator restraint provided</td></tr> <tr><td style="text-align: center;">Verify</td><td style="text-align: center;">Check</td><td>Instruments operational & labelled.</td></tr> <tr><td style="text-align: center;">Verify</td><td style="text-align: center;">Check</td><td>Levers / controls operational</td></tr> <tr><td style="text-align: center;">Verify</td><td style="text-align: center;">Check</td><td>Pedals in good condition</td></tr> <tr><td style="text-align: center;">Verify</td><td style="text-align: center;">Check</td><td>ROPS to AS 2294</td></tr> <tr><td style="text-align: center;">Verify</td><td style="text-align: center;">Check</td><td>Windows / wipers / washers</td></tr> <tr><td style="text-align: center;">Verify</td><td style="text-align: center;">Check</td><td>Rear view mirrors</td></tr> <tr><td style="text-align: center;">Verify</td><td style="text-align: center;">Check</td><td>Operator instruction (Available on plant)</td></tr> </table>	Verify	Check		Verify	Check	Cleanliness	Verify	Check	Seat condition OK	Verify	Check	Operator restraint provided	Verify	Check	Instruments operational & labelled.	Verify	Check	Levers / controls operational	Verify	Check	Pedals in good condition	Verify	Check	ROPS to AS 2294	Verify	Check	Windows / wipers / washers	Verify	Check	Rear view mirrors	Verify	Check	Operator instruction (Available on plant)	<p>Warning devices</p> <table style="width: 100%; border-collapse: collapse;"> <tr><td style="text-align: center;">Verify</td><td style="text-align: center;">Check</td><td></td></tr> <tr><td style="text-align: center;">Verify</td><td style="text-align: center;">Check</td><td>Horn</td></tr> <tr><td style="text-align: center;">Verify</td><td style="text-align: center;">Check</td><td>Amber flashing beacon < 12T</td></tr> <tr><td style="text-align: center;">Verify</td><td style="text-align: center;">Check</td><td>Reversing alarm</td></tr> </table> <p>Warning signs (in cabin)</p> <table style="width: 100%; border-collapse: collapse;"> <tr><td style="text-align: center;">Verify</td><td style="text-align: center;">Check</td><td></td></tr> <tr><td style="text-align: center;">Verify</td><td style="text-align: center;">Check</td><td></td></tr> </table> <div style="border: 1px solid black; padding: 5px; text-align: center; margin: 5px 0;">SEAT BELTS MUST BE WORN</div> <div style="border: 1px solid black; padding: 5px; text-align: center; margin: 5px 0;">DANGER – BEWARE OVERHEAD WIRES & UNDERGROUND SERVICES</div>	Verify	Check		Verify	Check	Horn	Verify	Check	Amber flashing beacon < 12T	Verify	Check	Reversing alarm	Verify	Check		Verify	Check		<table style="width: 100%; border-collapse: collapse;"> <tr><td style="text-align: center;">Verify</td><td style="text-align: center;">Check</td><td></td></tr> <tr><td style="text-align: center;">Verify</td><td style="text-align: center;">Check</td><td>Rams</td></tr> <tr><td style="text-align: center;">Verify</td><td style="text-align: center;">Check</td><td>Hoses</td></tr> <tr><td style="text-align: center;">Verify</td><td style="text-align: center;">Check</td><td>Connections (check for excessive wear, leaks and creep)</td></tr> </table>	Verify	Check		Verify	Check	Rams	Verify	Check	Hoses	Verify	Check	Connections (check for excessive wear, leaks and creep)	<ul style="list-style-type: none"> Plant to conform to manufacturer's specifications and Plant Regulations. Plant operator is to provide daily check sheets to Manildra on a weekly basis. Where applicable, Personal Protective Equipment must be worn. Plant Log Book detailing service history in accordance with Manufacturer's specifications should be written legibly in English. Contractor must produce proof of competence of operator, e.g., Certificate of Competence, Licence, detailed Log Book 		<p>Manildra use only</p> <p>NOTE: Sign only when all items have been checked</p> <p>Plant check by: _____</p> <p>Position: _____</p> <p>Date: _____ / ____ / ____</p>	<table style="width: 100%; border-collapse: collapse;"> <tr> <td style="width: 30%; vertical-align: top;"> <p>Tracks</p> <table style="width: 100%; border-collapse: collapse;"> <tr><td style="text-align: center;">Verify</td><td style="text-align: center;">Check</td><td></td></tr> <tr><td style="text-align: center;">Verify</td><td style="text-align: center;">Check</td><td>Pivots</td></tr> <tr><td style="text-align: center;">Verify</td><td style="text-align: center;">Check</td><td>Pins</td></tr> <tr><td style="text-align: center;">Verify</td><td style="text-align: center;">Check</td><td>Connections</td></tr> <tr><td style="text-align: center;">Verify</td><td style="text-align: center;">Check</td><td>Safety pins</td></tr> </table> </td> <td style="width: 35%; vertical-align: top;"> <table style="width: 100%; border-collapse: collapse;"> <tr><td style="text-align: center;">Verify</td><td style="text-align: center;">Check</td><td></td></tr> <tr><td style="text-align: center;">Verify</td><td style="text-align: center;">Check</td><td>Tracks complete</td></tr> <tr><td style="text-align: center;">Verify</td><td style="text-align: center;">Check</td><td>Idlers adjusted</td></tr> <tr><td style="text-align: center;">Verify</td><td style="text-align: center;">Check</td><td>Drivers free from leaks</td></tr> </table> </td> <td style="width: 35%; vertical-align: top;"> <table style="width: 100%; border-collapse: collapse;"> <tr><td style="text-align: center;">Verify</td><td style="text-align: center;">Check</td><td></td></tr> <tr><td style="text-align: center;">Verify</td><td style="text-align: center;">Check</td><td>Handrails</td></tr> <tr><td style="text-align: center;">Verify</td><td style="text-align: center;">Check</td><td>Steps</td></tr> </table> </td> </tr> </table> <div style="text-align: center; margin-top: 20px;"> </div> <p style="font-size: small; margin-top: 10px;">Instructions: Verify Box to be ticked by Owner / Supplier / Operator prior to arrival onsite. Check Box to be ticked after visual inspection by Manildra</p>	<p>Tracks</p> <table style="width: 100%; border-collapse: collapse;"> <tr><td style="text-align: center;">Verify</td><td style="text-align: center;">Check</td><td></td></tr> <tr><td style="text-align: center;">Verify</td><td style="text-align: center;">Check</td><td>Pivots</td></tr> <tr><td style="text-align: center;">Verify</td><td style="text-align: center;">Check</td><td>Pins</td></tr> <tr><td style="text-align: center;">Verify</td><td style="text-align: center;">Check</td><td>Connections</td></tr> <tr><td style="text-align: center;">Verify</td><td style="text-align: center;">Check</td><td>Safety pins</td></tr> </table>	Verify	Check		Verify	Check	Pivots	Verify	Check	Pins	Verify	Check	Connections	Verify	Check	Safety pins	<table style="width: 100%; border-collapse: collapse;"> <tr><td style="text-align: center;">Verify</td><td style="text-align: center;">Check</td><td></td></tr> <tr><td style="text-align: center;">Verify</td><td style="text-align: center;">Check</td><td>Tracks complete</td></tr> <tr><td style="text-align: center;">Verify</td><td style="text-align: center;">Check</td><td>Idlers adjusted</td></tr> <tr><td style="text-align: center;">Verify</td><td style="text-align: center;">Check</td><td>Drivers free from leaks</td></tr> </table>	Verify	Check		Verify	Check	Tracks complete	Verify	Check	Idlers adjusted	Verify	Check	Drivers free from leaks	<table style="width: 100%; border-collapse: collapse;"> <tr><td style="text-align: center;">Verify</td><td style="text-align: center;">Check</td><td></td></tr> <tr><td style="text-align: center;">Verify</td><td style="text-align: center;">Check</td><td>Handrails</td></tr> <tr><td style="text-align: center;">Verify</td><td style="text-align: center;">Check</td><td>Steps</td></tr> </table>	Verify	Check		Verify	Check	Handrails	Verify	Check	Steps
<p>Cab</p> <table style="width: 100%; border-collapse: collapse;"> <tr><td style="text-align: center;">Verify</td><td style="text-align: center;">Check</td><td></td></tr> <tr><td style="text-align: center;">Verify</td><td style="text-align: center;">Check</td><td>Cleanliness</td></tr> <tr><td style="text-align: center;">Verify</td><td style="text-align: center;">Check</td><td>Seat condition OK</td></tr> <tr><td style="text-align: center;">Verify</td><td style="text-align: center;">Check</td><td>Operator restraint provided</td></tr> <tr><td style="text-align: center;">Verify</td><td style="text-align: center;">Check</td><td>Instruments operational & labelled.</td></tr> <tr><td style="text-align: center;">Verify</td><td style="text-align: center;">Check</td><td>Levers / controls operational</td></tr> <tr><td style="text-align: center;">Verify</td><td style="text-align: center;">Check</td><td>Pedals in good condition</td></tr> <tr><td style="text-align: center;">Verify</td><td style="text-align: center;">Check</td><td>ROPS to AS 2294</td></tr> <tr><td style="text-align: center;">Verify</td><td style="text-align: center;">Check</td><td>Windows / wipers / washers</td></tr> <tr><td style="text-align: center;">Verify</td><td style="text-align: center;">Check</td><td>Rear view mirrors</td></tr> <tr><td style="text-align: center;">Verify</td><td style="text-align: center;">Check</td><td>Operator instruction (Available on plant)</td></tr> </table>	Verify	Check		Verify	Check	Cleanliness	Verify	Check	Seat condition OK	Verify	Check	Operator restraint provided	Verify	Check	Instruments operational & labelled.	Verify	Check	Levers / controls operational	Verify	Check	Pedals in good condition	Verify	Check	ROPS to AS 2294	Verify	Check	Windows / wipers / washers	Verify	Check	Rear view mirrors	Verify	Check	Operator instruction (Available on plant)	<p>Warning devices</p> <table style="width: 100%; border-collapse: collapse;"> <tr><td style="text-align: center;">Verify</td><td style="text-align: center;">Check</td><td></td></tr> <tr><td style="text-align: center;">Verify</td><td style="text-align: center;">Check</td><td>Horn</td></tr> <tr><td style="text-align: center;">Verify</td><td style="text-align: center;">Check</td><td>Amber flashing beacon < 12T</td></tr> <tr><td style="text-align: center;">Verify</td><td style="text-align: center;">Check</td><td>Reversing alarm</td></tr> </table> <p>Warning signs (in cabin)</p> <table style="width: 100%; border-collapse: collapse;"> <tr><td style="text-align: center;">Verify</td><td style="text-align: center;">Check</td><td></td></tr> <tr><td style="text-align: center;">Verify</td><td style="text-align: center;">Check</td><td></td></tr> </table> <div style="border: 1px solid black; padding: 5px; text-align: center; margin: 5px 0;">SEAT BELTS MUST BE WORN</div> <div style="border: 1px solid black; padding: 5px; text-align: center; margin: 5px 0;">DANGER – BEWARE OVERHEAD WIRES & UNDERGROUND SERVICES</div>	Verify	Check		Verify	Check	Horn	Verify	Check	Amber flashing beacon < 12T	Verify	Check	Reversing alarm	Verify	Check		Verify	Check		<table style="width: 100%; border-collapse: collapse;"> <tr><td style="text-align: center;">Verify</td><td style="text-align: center;">Check</td><td></td></tr> <tr><td style="text-align: center;">Verify</td><td style="text-align: center;">Check</td><td>Rams</td></tr> <tr><td style="text-align: center;">Verify</td><td style="text-align: center;">Check</td><td>Hoses</td></tr> <tr><td style="text-align: center;">Verify</td><td style="text-align: center;">Check</td><td>Connections (check for excessive wear, leaks and creep)</td></tr> </table>	Verify	Check		Verify	Check	Rams	Verify	Check	Hoses	Verify	Check	Connections (check for excessive wear, leaks and creep)																																													
Verify	Check																																																																																																													
Verify	Check	Cleanliness																																																																																																												
Verify	Check	Seat condition OK																																																																																																												
Verify	Check	Operator restraint provided																																																																																																												
Verify	Check	Instruments operational & labelled.																																																																																																												
Verify	Check	Levers / controls operational																																																																																																												
Verify	Check	Pedals in good condition																																																																																																												
Verify	Check	ROPS to AS 2294																																																																																																												
Verify	Check	Windows / wipers / washers																																																																																																												
Verify	Check	Rear view mirrors																																																																																																												
Verify	Check	Operator instruction (Available on plant)																																																																																																												
Verify	Check																																																																																																													
Verify	Check	Horn																																																																																																												
Verify	Check	Amber flashing beacon < 12T																																																																																																												
Verify	Check	Reversing alarm																																																																																																												
Verify	Check																																																																																																													
Verify	Check																																																																																																													
Verify	Check																																																																																																													
Verify	Check	Rams																																																																																																												
Verify	Check	Hoses																																																																																																												
Verify	Check	Connections (check for excessive wear, leaks and creep)																																																																																																												
<ul style="list-style-type: none"> Plant to conform to manufacturer's specifications and Plant Regulations. Plant operator is to provide daily check sheets to Manildra on a weekly basis. Where applicable, Personal Protective Equipment must be worn. Plant Log Book detailing service history in accordance with Manufacturer's specifications should be written legibly in English. Contractor must produce proof of competence of operator, e.g., Certificate of Competence, Licence, detailed Log Book 																																																																																																														
<p>Manildra use only</p> <p>NOTE: Sign only when all items have been checked</p> <p>Plant check by: _____</p> <p>Position: _____</p> <p>Date: _____ / ____ / ____</p>	<table style="width: 100%; border-collapse: collapse;"> <tr> <td style="width: 30%; vertical-align: top;"> <p>Tracks</p> <table style="width: 100%; border-collapse: collapse;"> <tr><td style="text-align: center;">Verify</td><td style="text-align: center;">Check</td><td></td></tr> <tr><td style="text-align: center;">Verify</td><td style="text-align: center;">Check</td><td>Pivots</td></tr> <tr><td style="text-align: center;">Verify</td><td style="text-align: center;">Check</td><td>Pins</td></tr> <tr><td style="text-align: center;">Verify</td><td style="text-align: center;">Check</td><td>Connections</td></tr> <tr><td style="text-align: center;">Verify</td><td style="text-align: center;">Check</td><td>Safety pins</td></tr> </table> </td> <td style="width: 35%; vertical-align: top;"> <table style="width: 100%; border-collapse: collapse;"> <tr><td style="text-align: center;">Verify</td><td style="text-align: center;">Check</td><td></td></tr> <tr><td style="text-align: center;">Verify</td><td style="text-align: center;">Check</td><td>Tracks complete</td></tr> <tr><td style="text-align: center;">Verify</td><td style="text-align: center;">Check</td><td>Idlers adjusted</td></tr> <tr><td style="text-align: center;">Verify</td><td style="text-align: center;">Check</td><td>Drivers free from leaks</td></tr> </table> </td> <td style="width: 35%; vertical-align: top;"> <table style="width: 100%; border-collapse: collapse;"> <tr><td style="text-align: center;">Verify</td><td style="text-align: center;">Check</td><td></td></tr> <tr><td style="text-align: center;">Verify</td><td style="text-align: center;">Check</td><td>Handrails</td></tr> <tr><td style="text-align: center;">Verify</td><td style="text-align: center;">Check</td><td>Steps</td></tr> </table> </td> </tr> </table> <div style="text-align: center; margin-top: 20px;"> </div> <p style="font-size: small; margin-top: 10px;">Instructions: Verify Box to be ticked by Owner / Supplier / Operator prior to arrival onsite. Check Box to be ticked after visual inspection by Manildra</p>	<p>Tracks</p> <table style="width: 100%; border-collapse: collapse;"> <tr><td style="text-align: center;">Verify</td><td style="text-align: center;">Check</td><td></td></tr> <tr><td style="text-align: center;">Verify</td><td style="text-align: center;">Check</td><td>Pivots</td></tr> <tr><td style="text-align: center;">Verify</td><td style="text-align: center;">Check</td><td>Pins</td></tr> <tr><td style="text-align: center;">Verify</td><td style="text-align: center;">Check</td><td>Connections</td></tr> <tr><td style="text-align: center;">Verify</td><td style="text-align: center;">Check</td><td>Safety pins</td></tr> </table>	Verify	Check		Verify	Check	Pivots	Verify	Check	Pins	Verify	Check	Connections	Verify	Check	Safety pins	<table style="width: 100%; border-collapse: collapse;"> <tr><td style="text-align: center;">Verify</td><td style="text-align: center;">Check</td><td></td></tr> <tr><td style="text-align: center;">Verify</td><td style="text-align: center;">Check</td><td>Tracks complete</td></tr> <tr><td style="text-align: center;">Verify</td><td style="text-align: center;">Check</td><td>Idlers adjusted</td></tr> <tr><td style="text-align: center;">Verify</td><td style="text-align: center;">Check</td><td>Drivers free from leaks</td></tr> </table>	Verify	Check		Verify	Check	Tracks complete	Verify	Check	Idlers adjusted	Verify	Check	Drivers free from leaks	<table style="width: 100%; border-collapse: collapse;"> <tr><td style="text-align: center;">Verify</td><td style="text-align: center;">Check</td><td></td></tr> <tr><td style="text-align: center;">Verify</td><td style="text-align: center;">Check</td><td>Handrails</td></tr> <tr><td style="text-align: center;">Verify</td><td style="text-align: center;">Check</td><td>Steps</td></tr> </table>	Verify	Check		Verify	Check	Handrails	Verify	Check	Steps																																																																						
<p>Tracks</p> <table style="width: 100%; border-collapse: collapse;"> <tr><td style="text-align: center;">Verify</td><td style="text-align: center;">Check</td><td></td></tr> <tr><td style="text-align: center;">Verify</td><td style="text-align: center;">Check</td><td>Pivots</td></tr> <tr><td style="text-align: center;">Verify</td><td style="text-align: center;">Check</td><td>Pins</td></tr> <tr><td style="text-align: center;">Verify</td><td style="text-align: center;">Check</td><td>Connections</td></tr> <tr><td style="text-align: center;">Verify</td><td style="text-align: center;">Check</td><td>Safety pins</td></tr> </table>	Verify	Check		Verify	Check	Pivots	Verify	Check	Pins	Verify	Check	Connections	Verify	Check	Safety pins	<table style="width: 100%; border-collapse: collapse;"> <tr><td style="text-align: center;">Verify</td><td style="text-align: center;">Check</td><td></td></tr> <tr><td style="text-align: center;">Verify</td><td style="text-align: center;">Check</td><td>Tracks complete</td></tr> <tr><td style="text-align: center;">Verify</td><td style="text-align: center;">Check</td><td>Idlers adjusted</td></tr> <tr><td style="text-align: center;">Verify</td><td style="text-align: center;">Check</td><td>Drivers free from leaks</td></tr> </table>	Verify	Check		Verify	Check	Tracks complete	Verify	Check	Idlers adjusted	Verify	Check	Drivers free from leaks	<table style="width: 100%; border-collapse: collapse;"> <tr><td style="text-align: center;">Verify</td><td style="text-align: center;">Check</td><td></td></tr> <tr><td style="text-align: center;">Verify</td><td style="text-align: center;">Check</td><td>Handrails</td></tr> <tr><td style="text-align: center;">Verify</td><td style="text-align: center;">Check</td><td>Steps</td></tr> </table>	Verify	Check		Verify	Check	Handrails	Verify	Check	Steps																																																																								
Verify	Check																																																																																																													
Verify	Check	Pivots																																																																																																												
Verify	Check	Pins																																																																																																												
Verify	Check	Connections																																																																																																												
Verify	Check	Safety pins																																																																																																												
Verify	Check																																																																																																													
Verify	Check	Tracks complete																																																																																																												
Verify	Check	Idlers adjusted																																																																																																												
Verify	Check	Drivers free from leaks																																																																																																												
Verify	Check																																																																																																													
Verify	Check	Handrails																																																																																																												
Verify	Check	Steps																																																																																																												

5. MOBILE PLANT CONCRETE BOOM PUMP

<p>Supplier verification & Plant details</p> <p>Plant owner: _____</p> <p>Address: _____</p> <p>City/Suburb: _____</p> <p>Phone: _____</p> <p>Plant make: _____</p> <p>Plant model: _____</p> <p>Serial no.: _____</p> <p>Signature: _____</p> <p>Date: _____</p> <p>SafeWork Certification – PB</p>	<p>Cab</p> <table style="width:100%; border-collapse: collapse;"> <tr> <td style="text-align: center;">Verify</td> <td style="text-align: center;">Check</td> <td></td> </tr> <tr> <td style="text-align: center;"><input type="checkbox"/></td> <td style="text-align: center;"><input type="checkbox"/></td> <td>Cleanliness</td> </tr> <tr> <td style="text-align: center;"><input type="checkbox"/></td> <td style="text-align: center;"><input type="checkbox"/></td> <td>Seat condition OK</td> </tr> <tr> <td style="text-align: center;"><input type="checkbox"/></td> <td style="text-align: center;"><input type="checkbox"/></td> <td>Operator restraint provided</td> </tr> <tr> <td style="text-align: center;"><input type="checkbox"/></td> <td style="text-align: center;"><input type="checkbox"/></td> <td>Instruments operational & labelled</td> </tr> <tr> <td style="text-align: center;"><input type="checkbox"/></td> <td style="text-align: center;"><input type="checkbox"/></td> <td>Levers / controls operational</td> </tr> <tr> <td style="text-align: center;"><input type="checkbox"/></td> <td style="text-align: center;"><input type="checkbox"/></td> <td>Pedals in good condition</td> </tr> <tr> <td style="text-align: center;"><input type="checkbox"/></td> <td style="text-align: center;"><input type="checkbox"/></td> <td>ROPS to AS 2294</td> </tr> <tr> <td style="text-align: center;"><input type="checkbox"/></td> <td style="text-align: center;"><input type="checkbox"/></td> <td>Windows / wipers / washers</td> </tr> <tr> <td style="text-align: center;"><input type="checkbox"/></td> <td style="text-align: center;"><input type="checkbox"/></td> <td>Rear view mirrors</td> </tr> <tr> <td style="text-align: center;"><input type="checkbox"/></td> <td style="text-align: center;"><input type="checkbox"/></td> <td>Operator instruction (available on plant)</td> </tr> </table>	Verify	Check		<input type="checkbox"/>	<input type="checkbox"/>	Cleanliness	<input type="checkbox"/>	<input type="checkbox"/>	Seat condition OK	<input type="checkbox"/>	<input type="checkbox"/>	Operator restraint provided	<input type="checkbox"/>	<input type="checkbox"/>	Instruments operational & labelled	<input type="checkbox"/>	<input type="checkbox"/>	Levers / controls operational	<input type="checkbox"/>	<input type="checkbox"/>	Pedals in good condition	<input type="checkbox"/>	<input type="checkbox"/>	ROPS to AS 2294	<input type="checkbox"/>	<input type="checkbox"/>	Windows / wipers / washers	<input type="checkbox"/>	<input type="checkbox"/>	Rear view mirrors	<input type="checkbox"/>	<input type="checkbox"/>	Operator instruction (available on plant)	<p style="text-align: center;">Diagram of Main Components Boom Pump With Slew Ring</p>	<p>Boom</p> <table style="width:100%; border-collapse: collapse;"> <tr> <td style="text-align: center;">Verify</td> <td style="text-align: center;">Check</td> <td></td> </tr> <tr> <td style="text-align: center;"><input type="checkbox"/></td> <td style="text-align: center;"><input type="checkbox"/></td> <td>Pivots</td> </tr> <tr> <td style="text-align: center;"><input type="checkbox"/></td> <td style="text-align: center;"><input type="checkbox"/></td> <td>Connecting rods</td> </tr> <tr> <td style="text-align: center;"><input type="checkbox"/></td> <td style="text-align: center;"><input type="checkbox"/></td> <td>Safety pins (no excessive wear)</td> </tr> </table> <p>Warning devices</p> <table style="width:100%; border-collapse: collapse;"> <tr> <td style="text-align: center;">Verify</td> <td style="text-align: center;">Check</td> <td></td> </tr> <tr> <td style="text-align: center;"><input type="checkbox"/></td> <td style="text-align: center;"><input type="checkbox"/></td> <td>Horn</td> </tr> <tr> <td style="text-align: center;"><input type="checkbox"/></td> <td style="text-align: center;"><input type="checkbox"/></td> <td>Amber flashing beacon</td> </tr> <tr> <td style="text-align: center;"><input type="checkbox"/></td> <td style="text-align: center;"><input type="checkbox"/></td> <td>Reversing alarm</td> </tr> </table> <p style="text-align: center;"><input type="checkbox"/> Emergency stops</p> <p style="text-align: center;">Verify Check DANGER – BEWARE OVERHEAD POWERLINES</p>	Verify	Check		<input type="checkbox"/>	<input type="checkbox"/>	Pivots	<input type="checkbox"/>	<input type="checkbox"/>	Connecting rods	<input type="checkbox"/>	<input type="checkbox"/>	Safety pins (no excessive wear)	Verify	Check		<input type="checkbox"/>	<input type="checkbox"/>	Horn	<input type="checkbox"/>	<input type="checkbox"/>	Amber flashing beacon	<input type="checkbox"/>	<input type="checkbox"/>	Reversing alarm
Verify	Check																																																											
<input type="checkbox"/>	<input type="checkbox"/>	Cleanliness																																																										
<input type="checkbox"/>	<input type="checkbox"/>	Seat condition OK																																																										
<input type="checkbox"/>	<input type="checkbox"/>	Operator restraint provided																																																										
<input type="checkbox"/>	<input type="checkbox"/>	Instruments operational & labelled																																																										
<input type="checkbox"/>	<input type="checkbox"/>	Levers / controls operational																																																										
<input type="checkbox"/>	<input type="checkbox"/>	Pedals in good condition																																																										
<input type="checkbox"/>	<input type="checkbox"/>	ROPS to AS 2294																																																										
<input type="checkbox"/>	<input type="checkbox"/>	Windows / wipers / washers																																																										
<input type="checkbox"/>	<input type="checkbox"/>	Rear view mirrors																																																										
<input type="checkbox"/>	<input type="checkbox"/>	Operator instruction (available on plant)																																																										
Verify	Check																																																											
<input type="checkbox"/>	<input type="checkbox"/>	Pivots																																																										
<input type="checkbox"/>	<input type="checkbox"/>	Connecting rods																																																										
<input type="checkbox"/>	<input type="checkbox"/>	Safety pins (no excessive wear)																																																										
Verify	Check																																																											
<input type="checkbox"/>	<input type="checkbox"/>	Horn																																																										
<input type="checkbox"/>	<input type="checkbox"/>	Amber flashing beacon																																																										
<input type="checkbox"/>	<input type="checkbox"/>	Reversing alarm																																																										
<ul style="list-style-type: none"> Plant to conform to manufacturer's specifications and Plant Regulations. Plant operator is to provide daily check sheets to Manildra on a weekly basis Where applicable, Personal Protective Equipment must be worn. Plant Log Book detailing service history in accordance with Manufacturer's specifications should be written legibly in English. Contractor must produce proof of competence of operator, e.g., Certificate of Competence, Licence, detailed Log Book 	<p style="text-align: center;">Verify Check</p> <p>Engine guarding <input type="checkbox"/> Exhaust <input type="checkbox"/></p>	<p style="text-align: center;">Verify Check</p> <p style="text-align: center;">BOOM PUMP WITH RACK AND PINION</p>	<p>Hydraulics</p> <table style="width:100%; border-collapse: collapse;"> <tr> <td style="text-align: center;">Verify</td> <td style="text-align: center;">Check</td> <td></td> </tr> <tr> <td style="text-align: center;"><input type="checkbox"/></td> <td style="text-align: center;"><input type="checkbox"/></td> <td>Rams</td> </tr> <tr> <td style="text-align: center;"><input type="checkbox"/></td> <td style="text-align: center;"><input type="checkbox"/></td> <td>Hoses</td> </tr> <tr> <td style="text-align: center;"><input type="checkbox"/></td> <td style="text-align: center;"><input type="checkbox"/></td> <td>Connections (check for excessive wear, leaks and creep)</td> </tr> </table>	Verify	Check		<input type="checkbox"/>	<input type="checkbox"/>	Rams	<input type="checkbox"/>	<input type="checkbox"/>	Hoses	<input type="checkbox"/>	<input type="checkbox"/>	Connections (check for excessive wear, leaks and creep)	<p style="text-align: center;">Verify Check</p> <p>Outriggers & rams <input type="checkbox"/></p> <p style="text-align: center;">Verify Check</p> <p>Slew radius / barricading <input type="checkbox"/></p>																																												
Verify	Check																																																											
<input type="checkbox"/>	<input type="checkbox"/>	Rams																																																										
<input type="checkbox"/>	<input type="checkbox"/>	Hoses																																																										
<input type="checkbox"/>	<input type="checkbox"/>	Connections (check for excessive wear, leaks and creep)																																																										
<p>Manildra use only</p> <p>NOTE: Sign only when all items have been checked</p> <p>Plant check by: _____</p> <p>Position: _____</p> <p>Date: _____ / _____ / _____</p>	<p style="text-align: center;">Verify Check</p> <table style="width:100%; border-collapse: collapse;"> <tr> <td style="text-align: center;"><input type="checkbox"/></td> <td style="text-align: center;"><input type="checkbox"/></td> <td>Slings / ropes / chains (tagged and in good working order)</td> </tr> <tr> <td style="text-align: center;"><input type="checkbox"/></td> <td style="text-align: center;"><input type="checkbox"/></td> <td>Electrical wiring (no visual signs of damage)</td> </tr> <tr> <td style="text-align: center;"><input type="checkbox"/></td> <td style="text-align: center;"><input type="checkbox"/></td> <td>Steel or timber pads</td> </tr> </table>	<input type="checkbox"/>	<input type="checkbox"/>	Slings / ropes / chains (tagged and in good working order)	<input type="checkbox"/>	<input type="checkbox"/>	Electrical wiring (no visual signs of damage)	<input type="checkbox"/>	<input type="checkbox"/>	Steel or timber pads	<p style="text-align: center;">Verify Check</p> <table style="width:100%; border-collapse: collapse;"> <tr> <td style="text-align: center;"><input type="checkbox"/></td> <td style="text-align: center;"><input type="checkbox"/></td> <td>Tyres</td> </tr> <tr> <td style="text-align: center;"><input type="checkbox"/></td> <td style="text-align: center;"><input type="checkbox"/></td> <td>Wheels</td> </tr> <tr> <td style="text-align: center;"><input type="checkbox"/></td> <td style="text-align: center;"><input type="checkbox"/></td> <td>Brakes</td> </tr> </table> <p>Instructions: Verify Box to be ticked by Owner / Supplier / Operator prior to arrival onsite.</p>	<input type="checkbox"/>	<input type="checkbox"/>	Tyres	<input type="checkbox"/>	<input type="checkbox"/>	Wheels	<input type="checkbox"/>	<input type="checkbox"/>	Brakes	<p style="text-align: center;">Verify Check</p> <p>Handrails <input type="checkbox"/></p> <p>Steps <input type="checkbox"/></p>																																							
<input type="checkbox"/>	<input type="checkbox"/>	Slings / ropes / chains (tagged and in good working order)																																																										
<input type="checkbox"/>	<input type="checkbox"/>	Electrical wiring (no visual signs of damage)																																																										
<input type="checkbox"/>	<input type="checkbox"/>	Steel or timber pads																																																										
<input type="checkbox"/>	<input type="checkbox"/>	Tyres																																																										
<input type="checkbox"/>	<input type="checkbox"/>	Wheels																																																										
<input type="checkbox"/>	<input type="checkbox"/>	Brakes																																																										

6. MOBILE PLANT COMPACTOR

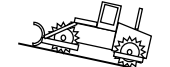
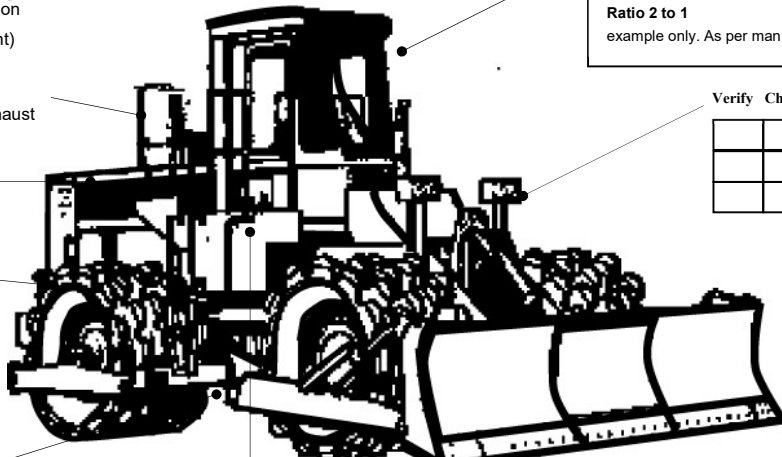
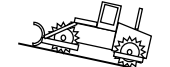
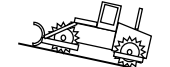
<p>Supplier verification & Plant details</p> <p>Plant owner: _____</p> <p>Address: _____</p> <p>City/Suburb: _____</p> <p>Phone: _____</p> <p>Plant make: _____</p> <p>Plant model: _____</p> <p>Serial no.: _____</p> <p>Signature: _____</p> <p>Date: _____</p> <p>Statement of operator competence required</p>	<table style="width: 100%; border-collapse: collapse;"> <tr> <td style="width: 30%; vertical-align: top;"> <p>Verify Check Cab</p> <table style="width: 100%; border-collapse: collapse;"> <tr><td style="width: 20px; height: 20px;"></td><td style="width: 20px; height: 20px;"></td><td>Cleanliness</td></tr> <tr><td style="width: 20px; height: 20px;"></td><td style="width: 20px; height: 20px;"></td><td>Seat condition OK</td></tr> <tr><td style="width: 20px; height: 20px;"></td><td style="width: 20px; height: 20px;"></td><td>Operator restraint provided</td></tr> <tr><td style="width: 20px; height: 20px;"></td><td style="width: 20px; height: 20px;"></td><td>Instruments operational & labeled</td></tr> <tr><td style="width: 20px; height: 20px;"></td><td style="width: 20px; height: 20px;"></td><td>Levers / controls operational</td></tr> <tr><td style="width: 20px; height: 20px;"></td><td style="width: 20px; height: 20px;"></td><td>Pedals in good condition</td></tr> <tr><td style="width: 20px; height: 20px;"></td><td style="width: 20px; height: 20px;"></td><td>ROPS to AS 2294</td></tr> <tr><td style="width: 20px; height: 20px;"></td><td style="width: 20px; height: 20px;"></td><td>Windows / wipers / washers</td></tr> <tr><td style="width: 20px; height: 20px;"></td><td style="width: 20px; height: 20px;"></td><td>Rear view mirrors</td></tr> <tr><td style="width: 20px; height: 20px;"></td><td style="width: 20px; height: 20px;"></td><td>Operator instruction (available on plant)</td></tr> </table> <p>Verify Check</p> <table style="width: 100%; border-collapse: collapse;"> <tr><td style="width: 20px; height: 20px;"></td><td style="width: 20px; height: 20px;"></td><td>Exhaust</td></tr> <tr><td style="width: 20px; height: 20px;"></td><td style="width: 20px; height: 20px;"></td><td>Engine guarding</td></tr> <tr><td style="width: 20px; height: 20px;"></td><td style="width: 20px; height: 20px;"></td><td>Brakes</td></tr> <tr><td style="width: 20px; height: 20px;"></td><td style="width: 20px; height: 20px;"></td><td>Park brake</td></tr> </table> <p>Verify Check</p> <table style="width: 100%; border-collapse: collapse;"> <tr><td style="width: 20px; height: 20px;"></td><td style="width: 20px; height: 20px;"></td><td>Crush point hazard sign displayed both sides</td></tr> </table> </td> <td style="width: 40%; vertical-align: top;"> <p>Warning devices</p> <p>Verify Check</p> <table style="width: 100%; border-collapse: collapse;"> <tr><td style="width: 20px; height: 20px;"></td><td style="width: 20px; height: 20px;"></td><td>Horn</td></tr> <tr><td style="width: 20px; height: 20px;"></td><td style="width: 20px; height: 20px;"></td><td>Reversing alarm</td></tr> </table> <p>Warning signs (in cabin)</p> <p>Verify Check</p> <table style="width: 100%; border-collapse: collapse;"> <tr><td style="width: 20px; height: 20px;"></td><td style="width: 20px; height: 20px;"></td><td style="border: 1px solid black; height: 20px;"></td></tr> </table> <p>Verify Check</p> <table style="width: 100%; border-collapse: collapse;"> <tr><td style="width: 20px; height: 20px;"></td><td style="width: 20px; height: 20px;"></td><td style="border: 1px solid black; height: 20px;"></td></tr> </table> <div style="border: 1px solid black; padding: 5px; margin-top: 10px;"> <p>DANGER – SAFE WORKING LIMITS ON BATTERS</p>  <p>Ratio 2 to 1 example only. As per manufacturer's specification</p> </div> </td> <td style="width: 30%; vertical-align: top;"> <p>Verify Check Hydraulics</p> <table style="width: 100%; border-collapse: collapse;"> <tr><td style="width: 20px; height: 20px;"></td><td style="width: 20px; height: 20px;"></td><td>Rams</td></tr> <tr><td style="width: 20px; height: 20px;"></td><td style="width: 20px; height: 20px;"></td><td>Hoses</td></tr> <tr><td style="width: 20px; height: 20px;"></td><td style="width: 20px; height: 20px;"></td><td>Connections (check for excessive wear, leaks and creep)</td></tr> </table> </td> </tr> </table> <div style="text-align: center; margin-top: 20px;">  </div> <div style="margin-top: 20px;"> <p>Manildra use only</p> <p>NOTE: Sign only when all items have been checked</p> <p>Plant check by: _____</p> <p>Position: _____</p> <p>Date: _____ / _____ / _____</p> </div> <div style="margin-top: 20px;"> <p>Instructions: Verify Box to be ticked by Owner / Supplier / Operator prior to arrival onsite. Check Box to be ticked after visual inspection by Manildra</p> </div>	<p>Verify Check Cab</p> <table style="width: 100%; border-collapse: collapse;"> <tr><td style="width: 20px; height: 20px;"></td><td style="width: 20px; height: 20px;"></td><td>Cleanliness</td></tr> <tr><td style="width: 20px; height: 20px;"></td><td style="width: 20px; height: 20px;"></td><td>Seat condition OK</td></tr> <tr><td style="width: 20px; height: 20px;"></td><td style="width: 20px; height: 20px;"></td><td>Operator restraint provided</td></tr> <tr><td style="width: 20px; height: 20px;"></td><td style="width: 20px; height: 20px;"></td><td>Instruments operational & labeled</td></tr> <tr><td style="width: 20px; height: 20px;"></td><td style="width: 20px; height: 20px;"></td><td>Levers / controls operational</td></tr> <tr><td style="width: 20px; height: 20px;"></td><td style="width: 20px; height: 20px;"></td><td>Pedals in good condition</td></tr> <tr><td style="width: 20px; height: 20px;"></td><td style="width: 20px; height: 20px;"></td><td>ROPS to AS 2294</td></tr> <tr><td style="width: 20px; height: 20px;"></td><td style="width: 20px; height: 20px;"></td><td>Windows / wipers / washers</td></tr> <tr><td style="width: 20px; height: 20px;"></td><td style="width: 20px; height: 20px;"></td><td>Rear view mirrors</td></tr> <tr><td style="width: 20px; height: 20px;"></td><td style="width: 20px; height: 20px;"></td><td>Operator instruction (available on plant)</td></tr> </table> <p>Verify Check</p> <table style="width: 100%; border-collapse: collapse;"> <tr><td style="width: 20px; height: 20px;"></td><td style="width: 20px; height: 20px;"></td><td>Exhaust</td></tr> <tr><td style="width: 20px; height: 20px;"></td><td style="width: 20px; height: 20px;"></td><td>Engine guarding</td></tr> <tr><td style="width: 20px; height: 20px;"></td><td style="width: 20px; height: 20px;"></td><td>Brakes</td></tr> <tr><td style="width: 20px; height: 20px;"></td><td style="width: 20px; height: 20px;"></td><td>Park brake</td></tr> </table> <p>Verify Check</p> <table style="width: 100%; border-collapse: collapse;"> <tr><td style="width: 20px; height: 20px;"></td><td style="width: 20px; height: 20px;"></td><td>Crush point hazard sign displayed both sides</td></tr> </table>			Cleanliness			Seat condition OK			Operator restraint provided			Instruments operational & labeled			Levers / controls operational			Pedals in good condition			ROPS to AS 2294			Windows / wipers / washers			Rear view mirrors			Operator instruction (available on plant)			Exhaust			Engine guarding			Brakes			Park brake			Crush point hazard sign displayed both sides	<p>Warning devices</p> <p>Verify Check</p> <table style="width: 100%; border-collapse: collapse;"> <tr><td style="width: 20px; height: 20px;"></td><td style="width: 20px; height: 20px;"></td><td>Horn</td></tr> <tr><td style="width: 20px; height: 20px;"></td><td style="width: 20px; height: 20px;"></td><td>Reversing alarm</td></tr> </table> <p>Warning signs (in cabin)</p> <p>Verify Check</p> <table style="width: 100%; border-collapse: collapse;"> <tr><td style="width: 20px; height: 20px;"></td><td style="width: 20px; height: 20px;"></td><td style="border: 1px solid black; height: 20px;"></td></tr> </table> <p>Verify Check</p> <table style="width: 100%; border-collapse: collapse;"> <tr><td style="width: 20px; height: 20px;"></td><td style="width: 20px; height: 20px;"></td><td style="border: 1px solid black; height: 20px;"></td></tr> </table> <div style="border: 1px solid black; padding: 5px; margin-top: 10px;"> <p>DANGER – SAFE WORKING LIMITS ON BATTERS</p>  <p>Ratio 2 to 1 example only. As per manufacturer's specification</p> </div>			Horn			Reversing alarm							<p>Verify Check Hydraulics</p> <table style="width: 100%; border-collapse: collapse;"> <tr><td style="width: 20px; height: 20px;"></td><td style="width: 20px; height: 20px;"></td><td>Rams</td></tr> <tr><td style="width: 20px; height: 20px;"></td><td style="width: 20px; height: 20px;"></td><td>Hoses</td></tr> <tr><td style="width: 20px; height: 20px;"></td><td style="width: 20px; height: 20px;"></td><td>Connections (check for excessive wear, leaks and creep)</td></tr> </table>			Rams			Hoses			Connections (check for excessive wear, leaks and creep)
<p>Verify Check Cab</p> <table style="width: 100%; border-collapse: collapse;"> <tr><td style="width: 20px; height: 20px;"></td><td style="width: 20px; height: 20px;"></td><td>Cleanliness</td></tr> <tr><td style="width: 20px; height: 20px;"></td><td style="width: 20px; height: 20px;"></td><td>Seat condition OK</td></tr> <tr><td style="width: 20px; height: 20px;"></td><td style="width: 20px; height: 20px;"></td><td>Operator restraint provided</td></tr> <tr><td style="width: 20px; height: 20px;"></td><td style="width: 20px; height: 20px;"></td><td>Instruments operational & labeled</td></tr> <tr><td style="width: 20px; height: 20px;"></td><td style="width: 20px; height: 20px;"></td><td>Levers / controls operational</td></tr> <tr><td style="width: 20px; height: 20px;"></td><td style="width: 20px; height: 20px;"></td><td>Pedals in good condition</td></tr> <tr><td style="width: 20px; height: 20px;"></td><td style="width: 20px; height: 20px;"></td><td>ROPS to AS 2294</td></tr> <tr><td style="width: 20px; height: 20px;"></td><td style="width: 20px; height: 20px;"></td><td>Windows / wipers / washers</td></tr> <tr><td style="width: 20px; height: 20px;"></td><td style="width: 20px; height: 20px;"></td><td>Rear view mirrors</td></tr> <tr><td style="width: 20px; height: 20px;"></td><td style="width: 20px; height: 20px;"></td><td>Operator instruction (available on plant)</td></tr> </table> <p>Verify Check</p> <table style="width: 100%; border-collapse: collapse;"> <tr><td style="width: 20px; height: 20px;"></td><td style="width: 20px; height: 20px;"></td><td>Exhaust</td></tr> <tr><td style="width: 20px; height: 20px;"></td><td style="width: 20px; height: 20px;"></td><td>Engine guarding</td></tr> <tr><td style="width: 20px; height: 20px;"></td><td style="width: 20px; height: 20px;"></td><td>Brakes</td></tr> <tr><td style="width: 20px; height: 20px;"></td><td style="width: 20px; height: 20px;"></td><td>Park brake</td></tr> </table> <p>Verify Check</p> <table style="width: 100%; border-collapse: collapse;"> <tr><td style="width: 20px; height: 20px;"></td><td style="width: 20px; height: 20px;"></td><td>Crush point hazard sign displayed both sides</td></tr> </table>			Cleanliness			Seat condition OK			Operator restraint provided			Instruments operational & labeled			Levers / controls operational			Pedals in good condition			ROPS to AS 2294			Windows / wipers / washers			Rear view mirrors			Operator instruction (available on plant)			Exhaust			Engine guarding			Brakes			Park brake			Crush point hazard sign displayed both sides	<p>Warning devices</p> <p>Verify Check</p> <table style="width: 100%; border-collapse: collapse;"> <tr><td style="width: 20px; height: 20px;"></td><td style="width: 20px; height: 20px;"></td><td>Horn</td></tr> <tr><td style="width: 20px; height: 20px;"></td><td style="width: 20px; height: 20px;"></td><td>Reversing alarm</td></tr> </table> <p>Warning signs (in cabin)</p> <p>Verify Check</p> <table style="width: 100%; border-collapse: collapse;"> <tr><td style="width: 20px; height: 20px;"></td><td style="width: 20px; height: 20px;"></td><td style="border: 1px solid black; height: 20px;"></td></tr> </table> <p>Verify Check</p> <table style="width: 100%; border-collapse: collapse;"> <tr><td style="width: 20px; height: 20px;"></td><td style="width: 20px; height: 20px;"></td><td style="border: 1px solid black; height: 20px;"></td></tr> </table> <div style="border: 1px solid black; padding: 5px; margin-top: 10px;"> <p>DANGER – SAFE WORKING LIMITS ON BATTERS</p>  <p>Ratio 2 to 1 example only. As per manufacturer's specification</p> </div>			Horn			Reversing alarm							<p>Verify Check Hydraulics</p> <table style="width: 100%; border-collapse: collapse;"> <tr><td style="width: 20px; height: 20px;"></td><td style="width: 20px; height: 20px;"></td><td>Rams</td></tr> <tr><td style="width: 20px; height: 20px;"></td><td style="width: 20px; height: 20px;"></td><td>Hoses</td></tr> <tr><td style="width: 20px; height: 20px;"></td><td style="width: 20px; height: 20px;"></td><td>Connections (check for excessive wear, leaks and creep)</td></tr> </table>			Rams			Hoses			Connections (check for excessive wear, leaks and creep)		
		Cleanliness																																																																				
		Seat condition OK																																																																				
		Operator restraint provided																																																																				
		Instruments operational & labeled																																																																				
		Levers / controls operational																																																																				
		Pedals in good condition																																																																				
		ROPS to AS 2294																																																																				
		Windows / wipers / washers																																																																				
		Rear view mirrors																																																																				
		Operator instruction (available on plant)																																																																				
		Exhaust																																																																				
		Engine guarding																																																																				
		Brakes																																																																				
		Park brake																																																																				
		Crush point hazard sign displayed both sides																																																																				
		Horn																																																																				
		Reversing alarm																																																																				
		Rams																																																																				
		Hoses																																																																				
		Connections (check for excessive wear, leaks and creep)																																																																				

7. MOBILE PLANT BUCKET TRENCHER (DITCH WITCH)

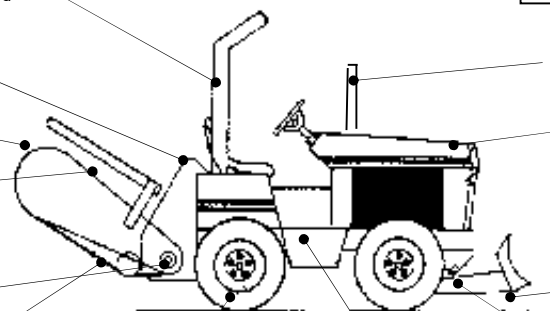
<p>Supplier Verification & Plant Details</p> <p>Plant Owner: _____</p> <p>Address: _____</p> <p>City/Suburb: _____</p> <p>Phone: _____</p> <p>Plant Make: _____</p> <p>Plant Model: _____</p> <p>Serial No.: _____</p> <p>Signature: _____</p> <p>Date: _____</p> <p>Statement of Operator Competence – Required</p>	<div style="display: flex; justify-content: space-between;"> <table border="1" style="margin-right: 20px;"> <tr><td>Verify Check</td><td></td></tr> <tr><td>Emergency Stop Buttons (both sides)</td><td></td></tr> <tr><td>Verify Check</td><td></td></tr> <tr><td>Crumber Bar</td><td></td></tr> <tr><td>Verify Check</td><td></td></tr> <tr><td>Positive Chain Guarding</td><td></td></tr> <tr><td>Verify Check</td><td></td></tr> <tr><td>Rams</td><td></td></tr> <tr><td>Hoses Connections (check for excessive wear, leaks and creep)</td><td></td></tr> <tr><td>Verify Check</td><td></td></tr> <tr><td>Linkages and Chain Pins in good condition</td><td></td></tr> <tr><td>Verify Check</td><td></td></tr> <tr><td>Tyres</td><td></td></tr> <tr><td>Wheels</td><td></td></tr> <tr><td>Brakes</td><td></td></tr> </table> <table border="1" style="margin-right: 20px;"> <tr><td>Verify Check</td><td></td></tr> <tr><td>Cleanliness</td><td></td></tr> <tr><td>Seat – Adjustments secure</td><td></td></tr> <tr><td>Operator Restraint</td><td></td></tr> <tr><td>Instruments & Labelling</td><td></td></tr> <tr><td>Lever / Controls</td><td></td></tr> <tr><td>Pedals</td><td></td></tr> <tr><td>ROPS AS2294</td><td></td></tr> <tr><td>Windows / Wipers / Washers if fitted</td><td></td></tr> </table> <table border="1" style="margin-right: 20px;"> <tr><td>Verify Check</td><td></td></tr> <tr><td>Horn</td><td></td></tr> <tr><td>Amber Flashing Beacon</td><td></td></tr> <tr><td>Reversing Alarm</td><td></td></tr> </table> </div> <div style="text-align: center;">  </div> <div style="margin-top: 20px;"> <table border="1" style="width: 100%;"> <tr> <td style="width: 30%;">CRUSH POINTS</td> <td style="width: 10%; text-align: center;">Verify Check</td> <td style="width: 60%;"></td> </tr> <tr> <td style="text-align: center;">KEEP CLEAR</td> <td style="text-align: center;"><input type="checkbox"/></td> <td></td> </tr> </table> <p style="text-align: center;">(Signs on both sides of vehicle)</p> </div> <div style="margin-top: 20px;"> <p>Instructions:</p> <p>Verify Box to be ticked by Owner / Supplier / Operator prior to arrival onsite. Check Box to be ticked after visual inspection by Manildra</p> </div>	Verify Check		Emergency Stop Buttons (both sides)		Verify Check		Crumber Bar		Verify Check		Positive Chain Guarding		Verify Check		Rams		Hoses Connections (check for excessive wear, leaks and creep)		Verify Check		Linkages and Chain Pins in good condition		Verify Check		Tyres		Wheels		Brakes		Verify Check		Cleanliness		Seat – Adjustments secure		Operator Restraint		Instruments & Labelling		Lever / Controls		Pedals		ROPS AS2294		Windows / Wipers / Washers if fitted		Verify Check		Horn		Amber Flashing Beacon		Reversing Alarm		CRUSH POINTS	Verify Check		KEEP CLEAR	<input type="checkbox"/>	
Verify Check																																																															
Emergency Stop Buttons (both sides)																																																															
Verify Check																																																															
Crumber Bar																																																															
Verify Check																																																															
Positive Chain Guarding																																																															
Verify Check																																																															
Rams																																																															
Hoses Connections (check for excessive wear, leaks and creep)																																																															
Verify Check																																																															
Linkages and Chain Pins in good condition																																																															
Verify Check																																																															
Tyres																																																															
Wheels																																																															
Brakes																																																															
Verify Check																																																															
Cleanliness																																																															
Seat – Adjustments secure																																																															
Operator Restraint																																																															
Instruments & Labelling																																																															
Lever / Controls																																																															
Pedals																																																															
ROPS AS2294																																																															
Windows / Wipers / Washers if fitted																																																															
Verify Check																																																															
Horn																																																															
Amber Flashing Beacon																																																															
Reversing Alarm																																																															
CRUSH POINTS	Verify Check																																																														
KEEP CLEAR	<input type="checkbox"/>																																																														
<p>■ Plant to conform to manufacturer's specifications and Plant Regs.</p> <p>■ Plant Operator is to provide daily check sheets to Manildra on a weekly basis</p> <p>■ Where applicable, Personal Protective Equipment must be worn.</p> <p>■ Plant Log Book Detailing service history in accordance with Manufacturer's specifications should be written legibly in English.</p> <p>■ Contractor must produce proof of competence of operator, e.g., Certificate of Competence, Licence, Detailed Log Book</p>	<div style="text-align: right; margin-bottom: 10px;"> <p>WARNING SIGNS (In Cabin)</p> <div style="border: 1px solid black; padding: 5px; display: inline-block;">SEAT BELTS MUST BE WORN</div> </div> <div style="border: 1px solid black; padding: 5px; display: inline-block; margin-bottom: 10px;"> DANGER – BEWARE UNDERGROUND WIRES & SERVICES BEFORE YOU DIG AUSTRALIA </div> <div style="text-align: right;"> <p>Verify Check</p> <table border="1" style="display: inline-table;"> <tr><td></td><td></td></tr> <tr><td></td><td></td></tr> </table> <p>Exhaust</p> <table border="1" style="display: inline-table;"> <tr><td></td><td></td></tr> </table> <p>Verify Check</p> <p>Engine Guarding</p> <table border="1" style="display: inline-table;"> <tr><td></td><td></td></tr> </table> <p>Verify Check</p> <p>Linkages</p> <table border="1" style="display: inline-table;"> <tr><td></td><td></td></tr> </table> <p>Verify Check</p> <p>Rams</p> <table border="1" style="display: inline-table;"> <tr><td></td><td></td></tr> <tr><td></td><td></td></tr> </table> <p>Verify Check</p> <p>Hoses Connections (check for excessive wear, leaks and creep)</p> <table border="1" style="display: inline-table;"> <tr><td></td><td></td></tr> <tr><td></td><td></td></tr> </table> <p>Verify Check</p> <p>Handrails</p> <table border="1" style="display: inline-table;"> <tr><td></td><td></td></tr> <tr><td></td><td></td></tr> </table> <p>Verify Check</p> <p>Steps</p> <table border="1" style="display: inline-table;"> <tr><td></td><td></td></tr> <tr><td></td><td></td></tr> </table> <p>Verify Check</p> </div>																																																														
<p>Manildra Use Only</p> <p>NOTE: Sign only when all items have been checked</p> <p>Plant Check By: _____</p> <p>Position: _____</p> <p>Date: _____ / ____ / ____</p>																																																															

10. MOBILE PLANT SKID STEER LOADER

<p>Supplier verification & Plant details</p> <p>Plant owner: _____</p> <p>Address: _____</p> <p>City/Suburb: _____</p> <p>Phone: _____</p> <p>Plant make: _____</p> <p>Plant model: _____</p> <p>Serial no.: _____</p> <p>Signature: _____</p> <p>Date: _____</p>	<table style="width: 100%; border-collapse: collapse;"> <tr> <td style="width: 30%; vertical-align: top;"> <table border="1" style="width: 100%; border-collapse: collapse;"> <tr><th style="text-align: left;">Verify</th><th style="text-align: left;">Check</th></tr> <tr><td> </td><td> </td></tr> <tr><td> </td><td> </td></tr> <tr><td> </td><td> </td></tr> <tr><td> </td><td> </td></tr> <tr><td> </td><td> </td></tr> <tr><td> </td><td> </td></tr> <tr><td> </td><td> </td></tr> <tr><td> </td><td> </td></tr> <tr><td> </td><td> </td></tr> <tr><td> </td><td> </td></tr> </table> </td> <td style="width: 40%; vertical-align: top;"> <p>Cab</p> <ul style="list-style-type: none"> Cleanliness Seat Operator restraint Instruments & labeling Levers / Controls Pedals Protective mesh Rear view mirrors ROPS to AS 2294 Operator instructions (Available on plant) </td> <td style="width: 30%; vertical-align: top;"> <table border="1" style="width: 100%; border-collapse: collapse;"> <tr><th style="text-align: left;">Verify</th><th style="text-align: left;">Check</th></tr> <tr><td> </td><td> </td></tr> <tr><td> </td><td> </td></tr> </table> <p>Warning signs (in cabin)</p> <div style="border: 1px solid black; padding: 2px; text-align: center; margin-bottom: 5px;">SEAT BELTS MUST BE WORN</div> <div style="border: 1px solid black; padding: 2px; text-align: center;">DANGER – BEWARE OVERHEAD WIRES</div> </td> </tr> <tr> <td style="vertical-align: top;"> <table border="1" style="width: 100%; border-collapse: collapse;"> <tr><th style="text-align: left;">Verify</th><th style="text-align: left;">Check</th></tr> <tr><td> </td><td> </td></tr> <tr><td> </td><td> </td></tr> <tr><td> </td><td> </td></tr> </table> </td> <td style="vertical-align: top;"> <p>Hydraulics</p> <ul style="list-style-type: none"> Rams Hoses Connections (check for excessive wear, leaks and creep) </td> <td style="vertical-align: top;"> <table border="1" style="width: 100%; border-collapse: collapse;"> <tr><th style="text-align: left;">Verify</th><th style="text-align: left;">Check</th></tr> <tr><td> </td><td> </td></tr> <tr><td> </td><td> </td></tr> <tr><td> </td><td> </td></tr> </table> </td> </tr> <tr> <td style="vertical-align: top;"> <table border="1" style="width: 100%; border-collapse: collapse;"> <tr><th style="text-align: left;">Verify</th><th style="text-align: left;">Check</th></tr> <tr><td> </td><td> </td></tr> <tr><td> </td><td> </td></tr> <tr><td> </td><td> </td></tr> </table> </td> <td style="vertical-align: top;"> <p>Hydraulics</p> <ul style="list-style-type: none"> Pivots Connecting rods Safety pins (no excessive wear) </td> <td style="vertical-align: top;"> <table border="1" style="width: 100%; border-collapse: collapse;"> <tr><th style="text-align: left;">Verify</th><th style="text-align: left;">Check</th></tr> <tr><td> </td><td> </td></tr> <tr><td> </td><td> </td></tr> <tr><td> </td><td> </td></tr> </table> </td> </tr> <tr> <td style="vertical-align: top;"> <table border="1" style="width: 100%; border-collapse: collapse;"> <tr><th style="text-align: left;">Verify</th><th style="text-align: left;">Check</th></tr> <tr><td> </td><td> </td></tr> <tr><td> </td><td> </td></tr> <tr><td> </td><td> </td></tr> <tr><td> </td><td> </td></tr> </table> </td> <td style="vertical-align: top;"> <p>Hydraulics</p> <ul style="list-style-type: none"> Rams Hoses Connections (check for excessive wear, leaks and creep) </td> <td style="vertical-align: top;"> <table border="1" style="width: 100%; border-collapse: collapse;"> <tr><th style="text-align: left;">Verify</th><th style="text-align: left;">Check</th></tr> <tr><td> </td><td> </td></tr> <tr><td> </td><td> </td></tr> <tr><td> </td><td> </td></tr> </table> </td> </tr> <tr> <td style="vertical-align: top;"> <table border="1" style="width: 100%; border-collapse: collapse;"> <tr><th style="text-align: left;">Verify</th><th style="text-align: left;">Check</th></tr> <tr><td> </td><td> </td></tr> <tr><td> </td><td> </td></tr> <tr><td> </td><td> </td></tr> <tr><td> </td><td> </td></tr> </table> </td> <td style="vertical-align: top;"> <p>Tyres</p> <ul style="list-style-type: none"> Wheels Brakes Park brake </td> <td style="vertical-align: top;"> <table border="1" style="width: 100%; border-collapse: collapse;"> <tr><th style="text-align: left;">Verify</th><th style="text-align: left;">Check</th></tr> <tr><td> </td><td> </td></tr> <tr><td> </td><td> </td></tr> <tr><td> </td><td> </td></tr> <tr><td> </td><td> </td></tr> </table> </td> </tr> <tr> <td style="vertical-align: top;"> <table border="1" style="width: 100%; border-collapse: collapse;"> <tr><th style="text-align: left;">Verify</th><th style="text-align: left;">Check</th></tr> <tr><td> </td><td> </td></tr> <tr><td> </td><td> </td></tr> </table> </td> <td style="vertical-align: top;"> <p>SWL / Crane chart</p> </td> <td style="vertical-align: top;"> <table border="1" style="width: 100%; border-collapse: collapse;"> <tr><th style="text-align: left;">Verify</th><th style="text-align: left;">Check</th></tr> <tr><td> </td><td> </td></tr> <tr><td> </td><td> </td></tr> </table> </td> </tr> </table> <div style="text-align: center; margin-top: 20px;"> </div> <p style="margin-top: 20px;">Instructions: Verify Box to be ticked by Owner / Supplier / Operator prior to arrival onsite. Check Box to be ticked after visual inspection by Manildra</p>	<table border="1" style="width: 100%; border-collapse: collapse;"> <tr><th style="text-align: left;">Verify</th><th style="text-align: left;">Check</th></tr> <tr><td> </td><td> </td></tr> <tr><td> </td><td> </td></tr> <tr><td> </td><td> </td></tr> <tr><td> </td><td> </td></tr> <tr><td> </td><td> </td></tr> <tr><td> </td><td> </td></tr> <tr><td> </td><td> </td></tr> <tr><td> </td><td> </td></tr> <tr><td> </td><td> </td></tr> <tr><td> </td><td> </td></tr> </table>	Verify	Check																					<p>Cab</p> <ul style="list-style-type: none"> Cleanliness Seat Operator restraint Instruments & labeling Levers / Controls Pedals Protective mesh Rear view mirrors ROPS to AS 2294 Operator instructions (Available on plant) 	<table border="1" style="width: 100%; border-collapse: collapse;"> <tr><th style="text-align: left;">Verify</th><th style="text-align: left;">Check</th></tr> <tr><td> </td><td> </td></tr> <tr><td> </td><td> </td></tr> </table> <p>Warning signs (in cabin)</p> <div style="border: 1px solid black; padding: 2px; text-align: center; margin-bottom: 5px;">SEAT BELTS MUST BE WORN</div> <div style="border: 1px solid black; padding: 2px; text-align: center;">DANGER – BEWARE OVERHEAD WIRES</div>	Verify	Check					<table border="1" style="width: 100%; border-collapse: collapse;"> <tr><th style="text-align: left;">Verify</th><th style="text-align: left;">Check</th></tr> <tr><td> </td><td> </td></tr> <tr><td> </td><td> </td></tr> <tr><td> </td><td> </td></tr> </table>	Verify	Check							<p>Hydraulics</p> <ul style="list-style-type: none"> Rams Hoses Connections (check for excessive wear, leaks and creep) 	<table border="1" style="width: 100%; border-collapse: collapse;"> <tr><th style="text-align: left;">Verify</th><th style="text-align: left;">Check</th></tr> <tr><td> </td><td> </td></tr> <tr><td> </td><td> </td></tr> <tr><td> </td><td> </td></tr> </table>	Verify	Check							<table border="1" style="width: 100%; border-collapse: collapse;"> <tr><th style="text-align: left;">Verify</th><th style="text-align: left;">Check</th></tr> <tr><td> </td><td> </td></tr> <tr><td> </td><td> </td></tr> <tr><td> </td><td> </td></tr> </table>	Verify	Check							<p>Hydraulics</p> <ul style="list-style-type: none"> Pivots Connecting rods Safety pins (no excessive wear) 	<table border="1" style="width: 100%; border-collapse: collapse;"> <tr><th style="text-align: left;">Verify</th><th style="text-align: left;">Check</th></tr> <tr><td> </td><td> </td></tr> <tr><td> </td><td> </td></tr> <tr><td> </td><td> </td></tr> </table>	Verify	Check							<table border="1" style="width: 100%; border-collapse: collapse;"> <tr><th style="text-align: left;">Verify</th><th style="text-align: left;">Check</th></tr> <tr><td> </td><td> </td></tr> <tr><td> </td><td> </td></tr> <tr><td> </td><td> </td></tr> <tr><td> </td><td> </td></tr> </table>	Verify	Check									<p>Hydraulics</p> <ul style="list-style-type: none"> Rams Hoses Connections (check for excessive wear, leaks and creep) 	<table border="1" style="width: 100%; border-collapse: collapse;"> <tr><th style="text-align: left;">Verify</th><th style="text-align: left;">Check</th></tr> <tr><td> </td><td> </td></tr> <tr><td> </td><td> </td></tr> <tr><td> </td><td> </td></tr> </table>	Verify	Check							<table border="1" style="width: 100%; border-collapse: collapse;"> <tr><th style="text-align: left;">Verify</th><th style="text-align: left;">Check</th></tr> <tr><td> </td><td> </td></tr> <tr><td> </td><td> </td></tr> <tr><td> </td><td> </td></tr> <tr><td> </td><td> </td></tr> </table>	Verify	Check									<p>Tyres</p> <ul style="list-style-type: none"> Wheels Brakes Park brake 	<table border="1" style="width: 100%; border-collapse: collapse;"> <tr><th style="text-align: left;">Verify</th><th style="text-align: left;">Check</th></tr> <tr><td> </td><td> </td></tr> <tr><td> </td><td> </td></tr> <tr><td> </td><td> </td></tr> <tr><td> </td><td> </td></tr> </table>	Verify	Check									<table border="1" style="width: 100%; border-collapse: collapse;"> <tr><th style="text-align: left;">Verify</th><th style="text-align: left;">Check</th></tr> <tr><td> </td><td> </td></tr> <tr><td> </td><td> </td></tr> </table>	Verify	Check					<p>SWL / Crane chart</p>	<table border="1" style="width: 100%; border-collapse: collapse;"> <tr><th style="text-align: left;">Verify</th><th style="text-align: left;">Check</th></tr> <tr><td> </td><td> </td></tr> <tr><td> </td><td> </td></tr> </table>	Verify	Check				
<table border="1" style="width: 100%; border-collapse: collapse;"> <tr><th style="text-align: left;">Verify</th><th style="text-align: left;">Check</th></tr> <tr><td> </td><td> </td></tr> <tr><td> </td><td> </td></tr> <tr><td> </td><td> </td></tr> <tr><td> </td><td> </td></tr> <tr><td> </td><td> </td></tr> <tr><td> </td><td> </td></tr> <tr><td> </td><td> </td></tr> <tr><td> </td><td> </td></tr> <tr><td> </td><td> </td></tr> <tr><td> </td><td> </td></tr> </table>	Verify	Check																					<p>Cab</p> <ul style="list-style-type: none"> Cleanliness Seat Operator restraint Instruments & labeling Levers / Controls Pedals Protective mesh Rear view mirrors ROPS to AS 2294 Operator instructions (Available on plant) 	<table border="1" style="width: 100%; border-collapse: collapse;"> <tr><th style="text-align: left;">Verify</th><th style="text-align: left;">Check</th></tr> <tr><td> </td><td> </td></tr> <tr><td> </td><td> </td></tr> </table> <p>Warning signs (in cabin)</p> <div style="border: 1px solid black; padding: 2px; text-align: center; margin-bottom: 5px;">SEAT BELTS MUST BE WORN</div> <div style="border: 1px solid black; padding: 2px; text-align: center;">DANGER – BEWARE OVERHEAD WIRES</div>	Verify	Check																																																																																																							
Verify	Check																																																																																																																																
Verify	Check																																																																																																																																
<table border="1" style="width: 100%; border-collapse: collapse;"> <tr><th style="text-align: left;">Verify</th><th style="text-align: left;">Check</th></tr> <tr><td> </td><td> </td></tr> <tr><td> </td><td> </td></tr> <tr><td> </td><td> </td></tr> </table>	Verify	Check							<p>Hydraulics</p> <ul style="list-style-type: none"> Rams Hoses Connections (check for excessive wear, leaks and creep) 	<table border="1" style="width: 100%; border-collapse: collapse;"> <tr><th style="text-align: left;">Verify</th><th style="text-align: left;">Check</th></tr> <tr><td> </td><td> </td></tr> <tr><td> </td><td> </td></tr> <tr><td> </td><td> </td></tr> </table>	Verify	Check																																																																																																																					
Verify	Check																																																																																																																																
Verify	Check																																																																																																																																
<table border="1" style="width: 100%; border-collapse: collapse;"> <tr><th style="text-align: left;">Verify</th><th style="text-align: left;">Check</th></tr> <tr><td> </td><td> </td></tr> <tr><td> </td><td> </td></tr> <tr><td> </td><td> </td></tr> </table>	Verify	Check							<p>Hydraulics</p> <ul style="list-style-type: none"> Pivots Connecting rods Safety pins (no excessive wear) 	<table border="1" style="width: 100%; border-collapse: collapse;"> <tr><th style="text-align: left;">Verify</th><th style="text-align: left;">Check</th></tr> <tr><td> </td><td> </td></tr> <tr><td> </td><td> </td></tr> <tr><td> </td><td> </td></tr> </table>	Verify	Check																																																																																																																					
Verify	Check																																																																																																																																
Verify	Check																																																																																																																																
<table border="1" style="width: 100%; border-collapse: collapse;"> <tr><th style="text-align: left;">Verify</th><th style="text-align: left;">Check</th></tr> <tr><td> </td><td> </td></tr> <tr><td> </td><td> </td></tr> <tr><td> </td><td> </td></tr> <tr><td> </td><td> </td></tr> </table>	Verify	Check									<p>Hydraulics</p> <ul style="list-style-type: none"> Rams Hoses Connections (check for excessive wear, leaks and creep) 	<table border="1" style="width: 100%; border-collapse: collapse;"> <tr><th style="text-align: left;">Verify</th><th style="text-align: left;">Check</th></tr> <tr><td> </td><td> </td></tr> <tr><td> </td><td> </td></tr> <tr><td> </td><td> </td></tr> </table>	Verify	Check																																																																																																																			
Verify	Check																																																																																																																																
Verify	Check																																																																																																																																
<table border="1" style="width: 100%; border-collapse: collapse;"> <tr><th style="text-align: left;">Verify</th><th style="text-align: left;">Check</th></tr> <tr><td> </td><td> </td></tr> <tr><td> </td><td> </td></tr> <tr><td> </td><td> </td></tr> <tr><td> </td><td> </td></tr> </table>	Verify	Check									<p>Tyres</p> <ul style="list-style-type: none"> Wheels Brakes Park brake 	<table border="1" style="width: 100%; border-collapse: collapse;"> <tr><th style="text-align: left;">Verify</th><th style="text-align: left;">Check</th></tr> <tr><td> </td><td> </td></tr> <tr><td> </td><td> </td></tr> <tr><td> </td><td> </td></tr> <tr><td> </td><td> </td></tr> </table>	Verify	Check																																																																																																																			
Verify	Check																																																																																																																																
Verify	Check																																																																																																																																
<table border="1" style="width: 100%; border-collapse: collapse;"> <tr><th style="text-align: left;">Verify</th><th style="text-align: left;">Check</th></tr> <tr><td> </td><td> </td></tr> <tr><td> </td><td> </td></tr> </table>	Verify	Check					<p>SWL / Crane chart</p>	<table border="1" style="width: 100%; border-collapse: collapse;"> <tr><th style="text-align: left;">Verify</th><th style="text-align: left;">Check</th></tr> <tr><td> </td><td> </td></tr> <tr><td> </td><td> </td></tr> </table>	Verify	Check																																																																																																																							
Verify	Check																																																																																																																																
Verify	Check																																																																																																																																
<p>Manildra use only</p> <p>NOTE: Sign only when all items have been checked</p> <p>Plant check by: _____</p> <p>Position: _____</p> <p>Date: _____ / ____ / ____</p>	<ul style="list-style-type: none"> • Plant to conform to manufacturer's specifications and Plant Regulations. • Plant operator is to provide daily checksheets to Manildra on a weekly basis. • Where applicable, Personal Protective Equipment must be worn. • Plant Log Book detailing service history in accordance with Manufacturer's specifications should be written legibly in English. • Contractor must produce proof of competence of operator, e.g., Certificate of Competence, Licence, detailed Log Book 																																																																																																																																

11. MOBILE PLANT SCISSOR LIFT

<p>Supplier verification & Plant details</p> <p>Plant owner: _____</p> <p>Address: _____</p> <p>City/Suburb: _____</p> <p>Phone: _____</p> <p>Plant make: _____</p> <p>Plant model: _____</p> <p>Serial no.: _____</p> <p>Signature: _____</p> <p>Date: _____</p> <p>Statement of operator competence required</p>	<div style="display: flex; justify-content: space-between;"> <div style="width: 20%;"> <p>Verify Check</p> <table border="1" style="width: 100%; height: 20px;"> <tr><td style="width: 50%;"></td><td style="width: 50%;"></td></tr> </table> <p>Levers / controls</p> </div> <div style="width: 20%;"> <p>Verify Check</p> <table border="1" style="width: 100%; height: 40px;"> <tr><td style="width: 50%;"></td><td style="width: 50%;"></td></tr> <tr><td style="width: 50%;"></td><td style="width: 50%;"></td></tr> <tr><td style="width: 50%;"></td><td style="width: 50%;"></td></tr> <tr><td style="width: 50%;"></td><td style="width: 50%;"></td></tr> </table> <p>Warning devices</p> <ul style="list-style-type: none"> Horn Amber flashing beacon (when onsite) Reversing alarm Head, tail & turn indicators </div> <div style="width: 20%;"> <p>Verify Check</p> <table border="1" style="width: 100%; height: 40px;"> <tr><td style="width: 50%;"></td><td style="width: 50%;"></td></tr> <tr><td style="width: 50%;"></td><td style="width: 50%;"></td></tr> <tr><td style="width: 50%;"></td><td style="width: 50%;"></td></tr> <tr><td style="width: 50%;"></td><td style="width: 50%;"></td></tr> </table> <p>Basket</p> <ul style="list-style-type: none"> Cleanliness Instruments & labeling Levers / controls basket & base Pedals Log book Operation instruction (Available on plant) </div> <div style="width: 20%;"> <p>Verify Check</p> <table border="1" style="width: 100%; height: 20px;"> <tr><td style="width: 50%;"></td><td style="width: 50%;"></td></tr> </table> <p>Self closing gate</p> </div> </div> <div style="display: flex; justify-content: space-between; margin-top: 10px;"> <div style="width: 20%;"> <p>Verify</p> <table border="1" style="width: 100%; height: 40px;"> <tr><td style="width: 50%;"></td><td style="width: 50%;"></td></tr> <tr><td style="width: 50%;"></td><td style="width: 50%;"></td></tr> <tr><td style="width: 50%;"></td><td style="width: 50%;"></td></tr> </table> <p>Pivots</p> <p>Connecting rods</p> <p>Safety pins</p> </div> <div style="width: 20%;"> <p>Verify Check</p> <table border="1" style="width: 100%; height: 20px;"> <tr><td style="width: 50%;"></td><td style="width: 50%;"></td></tr> </table> <p>Safety working load</p> </div> <div style="width: 20%; border: 1px solid black; padding: 5px; text-align: center;"> <p>WARNING & RESTRICTION SIGNS</p> </div> <div style="width: 20%;"> <p>Verify Check</p> <table border="1" style="width: 100%; height: 20px;"> <tr><td style="width: 50%;"></td><td style="width: 50%;"></td></tr> </table> <p>Safety prop under scissor</p> </div> </div> <div style="display: flex; justify-content: space-between; margin-top: 10px;"> <div style="width: 20%;"> <p>Verify</p> <table border="1" style="width: 100%; height: 40px;"> <tr><td style="width: 50%;"></td><td style="width: 50%;"></td></tr> <tr><td style="width: 50%;"></td><td style="width: 50%;"></td></tr> <tr><td style="width: 50%;"></td><td style="width: 50%;"></td></tr> </table> <p>Rams</p> <p>Hoses</p> <p>Connections (check for excessive)</p> </div> <div style="width: 20%;"> <p>Verify Check</p> <table border="1" style="width: 100%; height: 20px;"> <tr><td style="width: 50%;"></td><td style="width: 50%;"></td></tr> </table> <p>Exhaust (if applicable)</p> </div> <div style="width: 20%;"> <p>Verify Check</p> <table border="1" style="width: 100%; height: 40px;"> <tr><td style="width: 50%;"></td><td style="width: 50%;"></td></tr> <tr><td style="width: 50%;"></td><td style="width: 50%;"></td></tr> <tr><td style="width: 50%;"></td><td style="width: 50%;"></td></tr> <tr><td style="width: 50%;"></td><td style="width: 50%;"></td></tr> </table> <p>Tyres</p> <p>Wheels</p> <p>Brakes</p> <p>Park brake</p> </div> </div> <div style="margin-top: 10px;"> <p>Verify Check</p> <table border="1" style="width: 100%; height: 20px;"> <tr><td style="width: 50%;"></td><td style="width: 50%;"></td></tr> </table> <p>Engine guarding</p> </div> <div style="margin-top: 10px;"> <p>Instructions:</p> <p>Verify Box to be ticked by Owner / Supplier / Operator prior to arrival onsite. Check Box to be ticked after visual inspection by Manildra</p> </div>																																																
<ul style="list-style-type: none"> Plant to conform to manufacturer's specifications and Plant Regulations. Plant operator is to provide daily check sheets to Manildra on a weekly basis Where applicable, Personal Protective Equipment must be worn. Plant Log Book detailing service history in accordance with Manufacturer's specifications should be written legibly in English. Contractor must produce proof of competence of operator, e.g., Certificate of Competence, Licence, detailed Log Book 																																																	
<p>Manildra use only</p> <p>NOTE: Sign only when all items have been checked</p> <p>Plant check by: _____</p> <p>Position: _____</p> <p>Date: _____ / ____ / ____</p>																																																	

12. MOBILE CRANE

<p>Supplier verification & Plant details</p> <p>Plant owner: _____</p> <p>Address: _____</p> <p>City/Suburb: _____</p> <p>Phone: _____</p> <p>Plant make: _____</p> <p>Plant model: _____</p> <p>Serial no.: _____</p> <p>Signature: _____</p> <p>Date: _____</p> <p>SafeWork Certification – C2, C6, C1, CO</p>	<table style="width: 100%; border-collapse: collapse;"> <tr> <td style="width: 25%; vertical-align: top; padding: 5px;"> <p>Verify Check Boom</p> <table style="width: 100%; border-collapse: collapse;"> <tr><td style="width: 20px;"><input type="checkbox"/></td><td style="width: 20px;"><input type="checkbox"/></td><td>Pivots</td></tr> <tr><td><input type="checkbox"/></td><td><input type="checkbox"/></td><td>Connecting rods</td></tr> <tr><td><input type="checkbox"/></td><td><input type="checkbox"/></td><td>Safety pins (no excessive wear)</td></tr> </table> </td> <td style="width: 25%; vertical-align: top; padding: 5px;"> <p>Verify Check Cab</p> <table style="width: 100%; border-collapse: collapse;"> <tr><td style="width: 20px;"><input type="checkbox"/></td><td style="width: 20px;"><input type="checkbox"/></td><td>Cleanliness</td></tr> <tr><td><input type="checkbox"/></td><td><input type="checkbox"/></td><td>Seat condition OK</td></tr> <tr><td><input type="checkbox"/></td><td><input type="checkbox"/></td><td>Operator restraint provided</td></tr> <tr><td><input type="checkbox"/></td><td><input type="checkbox"/></td><td>Instruments operational & labeled</td></tr> <tr><td><input type="checkbox"/></td><td><input type="checkbox"/></td><td>Levers / controls operational</td></tr> <tr><td><input type="checkbox"/></td><td><input type="checkbox"/></td><td>Pedals in good condition</td></tr> <tr><td><input type="checkbox"/></td><td><input type="checkbox"/></td><td>ROPS to AS 2294</td></tr> <tr><td><input type="checkbox"/></td><td><input type="checkbox"/></td><td>Windows / wipers / washers</td></tr> <tr><td><input type="checkbox"/></td><td><input type="checkbox"/></td><td>Rear view mirrors</td></tr> <tr><td><input type="checkbox"/></td><td><input type="checkbox"/></td><td>Operator instruction (available on plant)</td></tr> <tr><td><input type="checkbox"/></td><td><input type="checkbox"/></td><td>Log book</td></tr> <tr><td><input type="checkbox"/></td><td><input type="checkbox"/></td><td>SWL / crane chart</td></tr> </table> </td> <td style="width: 25%; vertical-align: top; padding: 5px;"> <p>Verify Check Warning devices</p> <table style="width: 100%; border-collapse: collapse;"> <tr><td style="width: 20px;"><input type="checkbox"/></td><td style="width: 20px;"><input type="checkbox"/></td><td>Horn</td></tr> <tr><td><input type="checkbox"/></td><td><input type="checkbox"/></td><td>Amber flashing beacon</td></tr> <tr><td><input type="checkbox"/></td><td><input type="checkbox"/></td><td>Reversing alarm</td></tr> </table> <p>Verify Check Warning signs (in cabin)</p> <table style="width: 100%; border-collapse: collapse;"> <tr><td style="width: 20px;"><input type="checkbox"/></td><td style="width: 20px;"><input type="checkbox"/></td><td style="border: 1px solid black; padding: 2px; text-align: center;">SEAT BELTS MUST BE WORN</td></tr> <tr><td><input type="checkbox"/></td><td><input type="checkbox"/></td><td style="border: 1px solid black; padding: 2px; text-align: center;">DANGER – BEWARE OVERHEAD WIRES, PIPES and SERVICES</td></tr> </table> </td> </tr> <tr> <td style="vertical-align: top; padding: 5px;"> <p>Verify Check</p> <table style="width: 100%; border-collapse: collapse;"> <tr><td style="width: 20px;"><input type="checkbox"/></td><td style="width: 20px;"><input type="checkbox"/></td><td>Hambone & wedge</td></tr> </table> </td> <td style="vertical-align: top; padding: 5px;"> <p>Verify Check Hydraulics</p> <table style="width: 100%; border-collapse: collapse;"> <tr><td style="width: 20px;"><input type="checkbox"/></td><td style="width: 20px;"><input type="checkbox"/></td><td>Rams</td></tr> <tr><td><input type="checkbox"/></td><td><input type="checkbox"/></td><td>Hoses</td></tr> <tr><td><input type="checkbox"/></td><td><input type="checkbox"/></td><td>Connections (check for excessive wear, leaks and creep)</td></tr> </table> </td> <td style="vertical-align: top; padding: 5px;"> <p>Verify Check</p> <table style="width: 100%; border-collapse: collapse;"> <tr><td style="width: 20px;"><input type="checkbox"/></td><td style="width: 20px;"><input type="checkbox"/></td><td>Tyres</td></tr> <tr><td><input type="checkbox"/></td><td><input type="checkbox"/></td><td>Wheels</td></tr> <tr><td><input type="checkbox"/></td><td><input type="checkbox"/></td><td>Brakes</td></tr> <tr><td><input type="checkbox"/></td><td><input type="checkbox"/></td><td>Park brake</td></tr> </table> </td> </tr> <tr> <td style="vertical-align: top; padding: 5px;"> <p>Verify Check</p> <table style="width: 100%; border-collapse: collapse;"> <tr><td style="width: 20px;"><input type="checkbox"/></td><td style="width: 20px;"><input type="checkbox"/></td><td>Slings / ropes / chains (tagged and in good working order)</td></tr> <tr><td><input type="checkbox"/></td><td><input type="checkbox"/></td><td>Electrical wiring (no visual signs of damage)</td></tr> <tr><td><input type="checkbox"/></td><td><input type="checkbox"/></td><td>Steel or timber pads</td></tr> </table> </td> <td style="vertical-align: top; padding: 5px;"> <p>Verify Check</p> <table style="width: 100%; border-collapse: collapse;"> <tr><td style="width: 20px;"><input type="checkbox"/></td><td style="width: 20px;"><input type="checkbox"/></td><td>Handrails</td></tr> <tr><td><input type="checkbox"/></td><td><input type="checkbox"/></td><td>Steps</td></tr> </table> </td> <td style="vertical-align: top; padding: 5px;"> <p>Verify Check</p> <table style="width: 100%; border-collapse: collapse;"> <tr><td style="width: 20px;"><input type="checkbox"/></td><td style="width: 20px;"><input type="checkbox"/></td><td>Engine guarding</td></tr> <tr><td><input type="checkbox"/></td><td><input type="checkbox"/></td><td>Exhaust</td></tr> <tr><td><input type="checkbox"/></td><td><input type="checkbox"/></td><td>Slew radius / barricading for around outriggers</td></tr> </table> </td> </tr> </table> <div style="text-align: center; margin-top: 20px;"> </div> <p style="margin-top: 20px;">Instructions: Verify Box to be ticked by Owner / Supplier / Operator prior to arrival onsite. Check Box to be ticked after visual inspection by Manildra</p>	<p>Verify Check Boom</p> <table style="width: 100%; border-collapse: collapse;"> <tr><td style="width: 20px;"><input type="checkbox"/></td><td style="width: 20px;"><input type="checkbox"/></td><td>Pivots</td></tr> <tr><td><input type="checkbox"/></td><td><input type="checkbox"/></td><td>Connecting rods</td></tr> <tr><td><input type="checkbox"/></td><td><input type="checkbox"/></td><td>Safety pins (no excessive wear)</td></tr> </table>	<input type="checkbox"/>	<input type="checkbox"/>	Pivots	<input type="checkbox"/>	<input type="checkbox"/>	Connecting rods	<input type="checkbox"/>	<input type="checkbox"/>	Safety pins (no excessive wear)	<p>Verify Check Cab</p> <table style="width: 100%; border-collapse: collapse;"> <tr><td style="width: 20px;"><input type="checkbox"/></td><td style="width: 20px;"><input type="checkbox"/></td><td>Cleanliness</td></tr> <tr><td><input type="checkbox"/></td><td><input type="checkbox"/></td><td>Seat condition OK</td></tr> <tr><td><input type="checkbox"/></td><td><input type="checkbox"/></td><td>Operator restraint provided</td></tr> <tr><td><input type="checkbox"/></td><td><input type="checkbox"/></td><td>Instruments operational & labeled</td></tr> <tr><td><input type="checkbox"/></td><td><input type="checkbox"/></td><td>Levers / controls operational</td></tr> <tr><td><input type="checkbox"/></td><td><input type="checkbox"/></td><td>Pedals in good condition</td></tr> <tr><td><input type="checkbox"/></td><td><input type="checkbox"/></td><td>ROPS to AS 2294</td></tr> <tr><td><input type="checkbox"/></td><td><input type="checkbox"/></td><td>Windows / wipers / washers</td></tr> <tr><td><input type="checkbox"/></td><td><input type="checkbox"/></td><td>Rear view mirrors</td></tr> <tr><td><input type="checkbox"/></td><td><input type="checkbox"/></td><td>Operator instruction (available on plant)</td></tr> <tr><td><input type="checkbox"/></td><td><input type="checkbox"/></td><td>Log book</td></tr> <tr><td><input type="checkbox"/></td><td><input type="checkbox"/></td><td>SWL / crane chart</td></tr> </table>	<input type="checkbox"/>	<input type="checkbox"/>	Cleanliness	<input type="checkbox"/>	<input type="checkbox"/>	Seat condition OK	<input type="checkbox"/>	<input type="checkbox"/>	Operator restraint provided	<input type="checkbox"/>	<input type="checkbox"/>	Instruments operational & labeled	<input type="checkbox"/>	<input type="checkbox"/>	Levers / controls operational	<input type="checkbox"/>	<input type="checkbox"/>	Pedals in good condition	<input type="checkbox"/>	<input type="checkbox"/>	ROPS to AS 2294	<input type="checkbox"/>	<input type="checkbox"/>	Windows / wipers / washers	<input type="checkbox"/>	<input type="checkbox"/>	Rear view mirrors	<input type="checkbox"/>	<input type="checkbox"/>	Operator instruction (available on plant)	<input type="checkbox"/>	<input type="checkbox"/>	Log book	<input type="checkbox"/>	<input type="checkbox"/>	SWL / crane chart	<p>Verify Check Warning devices</p> <table style="width: 100%; border-collapse: collapse;"> <tr><td style="width: 20px;"><input type="checkbox"/></td><td style="width: 20px;"><input type="checkbox"/></td><td>Horn</td></tr> <tr><td><input type="checkbox"/></td><td><input type="checkbox"/></td><td>Amber flashing beacon</td></tr> <tr><td><input type="checkbox"/></td><td><input type="checkbox"/></td><td>Reversing alarm</td></tr> </table> <p>Verify Check Warning signs (in cabin)</p> <table style="width: 100%; border-collapse: collapse;"> <tr><td style="width: 20px;"><input type="checkbox"/></td><td style="width: 20px;"><input type="checkbox"/></td><td style="border: 1px solid black; padding: 2px; text-align: center;">SEAT BELTS MUST BE WORN</td></tr> <tr><td><input type="checkbox"/></td><td><input type="checkbox"/></td><td style="border: 1px solid black; padding: 2px; text-align: center;">DANGER – BEWARE OVERHEAD WIRES, PIPES and SERVICES</td></tr> </table>	<input type="checkbox"/>	<input type="checkbox"/>	Horn	<input type="checkbox"/>	<input type="checkbox"/>	Amber flashing beacon	<input type="checkbox"/>	<input type="checkbox"/>	Reversing alarm	<input type="checkbox"/>	<input type="checkbox"/>	SEAT BELTS MUST BE WORN	<input type="checkbox"/>	<input type="checkbox"/>	DANGER – BEWARE OVERHEAD WIRES, PIPES and SERVICES	<p>Verify Check</p> <table style="width: 100%; border-collapse: collapse;"> <tr><td style="width: 20px;"><input type="checkbox"/></td><td style="width: 20px;"><input type="checkbox"/></td><td>Hambone & wedge</td></tr> </table>	<input type="checkbox"/>	<input type="checkbox"/>	Hambone & wedge	<p>Verify Check Hydraulics</p> <table style="width: 100%; border-collapse: collapse;"> <tr><td style="width: 20px;"><input type="checkbox"/></td><td style="width: 20px;"><input type="checkbox"/></td><td>Rams</td></tr> <tr><td><input type="checkbox"/></td><td><input type="checkbox"/></td><td>Hoses</td></tr> <tr><td><input type="checkbox"/></td><td><input type="checkbox"/></td><td>Connections (check for excessive wear, leaks and creep)</td></tr> </table>	<input type="checkbox"/>	<input type="checkbox"/>	Rams	<input type="checkbox"/>	<input type="checkbox"/>	Hoses	<input type="checkbox"/>	<input type="checkbox"/>	Connections (check for excessive wear, leaks and creep)	<p>Verify Check</p> <table style="width: 100%; border-collapse: collapse;"> <tr><td style="width: 20px;"><input type="checkbox"/></td><td style="width: 20px;"><input type="checkbox"/></td><td>Tyres</td></tr> <tr><td><input type="checkbox"/></td><td><input type="checkbox"/></td><td>Wheels</td></tr> <tr><td><input type="checkbox"/></td><td><input type="checkbox"/></td><td>Brakes</td></tr> <tr><td><input type="checkbox"/></td><td><input type="checkbox"/></td><td>Park brake</td></tr> </table>	<input type="checkbox"/>	<input type="checkbox"/>	Tyres	<input type="checkbox"/>	<input type="checkbox"/>	Wheels	<input type="checkbox"/>	<input type="checkbox"/>	Brakes	<input type="checkbox"/>	<input type="checkbox"/>	Park brake	<p>Verify Check</p> <table style="width: 100%; border-collapse: collapse;"> <tr><td style="width: 20px;"><input type="checkbox"/></td><td style="width: 20px;"><input type="checkbox"/></td><td>Slings / ropes / chains (tagged and in good working order)</td></tr> <tr><td><input type="checkbox"/></td><td><input type="checkbox"/></td><td>Electrical wiring (no visual signs of damage)</td></tr> <tr><td><input type="checkbox"/></td><td><input type="checkbox"/></td><td>Steel or timber pads</td></tr> </table>	<input type="checkbox"/>	<input type="checkbox"/>	Slings / ropes / chains (tagged and in good working order)	<input type="checkbox"/>	<input type="checkbox"/>	Electrical wiring (no visual signs of damage)	<input type="checkbox"/>	<input type="checkbox"/>	Steel or timber pads	<p>Verify Check</p> <table style="width: 100%; border-collapse: collapse;"> <tr><td style="width: 20px;"><input type="checkbox"/></td><td style="width: 20px;"><input type="checkbox"/></td><td>Handrails</td></tr> <tr><td><input type="checkbox"/></td><td><input type="checkbox"/></td><td>Steps</td></tr> </table>	<input type="checkbox"/>	<input type="checkbox"/>	Handrails	<input type="checkbox"/>	<input type="checkbox"/>	Steps	<p>Verify Check</p> <table style="width: 100%; border-collapse: collapse;"> <tr><td style="width: 20px;"><input type="checkbox"/></td><td style="width: 20px;"><input type="checkbox"/></td><td>Engine guarding</td></tr> <tr><td><input type="checkbox"/></td><td><input type="checkbox"/></td><td>Exhaust</td></tr> <tr><td><input type="checkbox"/></td><td><input type="checkbox"/></td><td>Slew radius / barricading for around outriggers</td></tr> </table>	<input type="checkbox"/>	<input type="checkbox"/>	Engine guarding	<input type="checkbox"/>	<input type="checkbox"/>	Exhaust	<input type="checkbox"/>	<input type="checkbox"/>	Slew radius / barricading for around outriggers
<p>Verify Check Boom</p> <table style="width: 100%; border-collapse: collapse;"> <tr><td style="width: 20px;"><input type="checkbox"/></td><td style="width: 20px;"><input type="checkbox"/></td><td>Pivots</td></tr> <tr><td><input type="checkbox"/></td><td><input type="checkbox"/></td><td>Connecting rods</td></tr> <tr><td><input type="checkbox"/></td><td><input type="checkbox"/></td><td>Safety pins (no excessive wear)</td></tr> </table>	<input type="checkbox"/>	<input type="checkbox"/>	Pivots	<input type="checkbox"/>	<input type="checkbox"/>	Connecting rods	<input type="checkbox"/>	<input type="checkbox"/>	Safety pins (no excessive wear)	<p>Verify Check Cab</p> <table style="width: 100%; border-collapse: collapse;"> <tr><td style="width: 20px;"><input type="checkbox"/></td><td style="width: 20px;"><input type="checkbox"/></td><td>Cleanliness</td></tr> <tr><td><input type="checkbox"/></td><td><input type="checkbox"/></td><td>Seat condition OK</td></tr> <tr><td><input type="checkbox"/></td><td><input type="checkbox"/></td><td>Operator restraint provided</td></tr> <tr><td><input type="checkbox"/></td><td><input type="checkbox"/></td><td>Instruments operational & labeled</td></tr> <tr><td><input type="checkbox"/></td><td><input type="checkbox"/></td><td>Levers / controls operational</td></tr> <tr><td><input type="checkbox"/></td><td><input type="checkbox"/></td><td>Pedals in good condition</td></tr> <tr><td><input type="checkbox"/></td><td><input type="checkbox"/></td><td>ROPS to AS 2294</td></tr> <tr><td><input type="checkbox"/></td><td><input type="checkbox"/></td><td>Windows / wipers / washers</td></tr> <tr><td><input type="checkbox"/></td><td><input type="checkbox"/></td><td>Rear view mirrors</td></tr> <tr><td><input type="checkbox"/></td><td><input type="checkbox"/></td><td>Operator instruction (available on plant)</td></tr> <tr><td><input type="checkbox"/></td><td><input type="checkbox"/></td><td>Log book</td></tr> <tr><td><input type="checkbox"/></td><td><input type="checkbox"/></td><td>SWL / crane chart</td></tr> </table>	<input type="checkbox"/>	<input type="checkbox"/>	Cleanliness	<input type="checkbox"/>	<input type="checkbox"/>	Seat condition OK	<input type="checkbox"/>	<input type="checkbox"/>	Operator restraint provided	<input type="checkbox"/>	<input type="checkbox"/>	Instruments operational & labeled	<input type="checkbox"/>	<input type="checkbox"/>	Levers / controls operational	<input type="checkbox"/>	<input type="checkbox"/>	Pedals in good condition	<input type="checkbox"/>	<input type="checkbox"/>	ROPS to AS 2294	<input type="checkbox"/>	<input type="checkbox"/>	Windows / wipers / washers	<input type="checkbox"/>	<input type="checkbox"/>	Rear view mirrors	<input type="checkbox"/>	<input type="checkbox"/>	Operator instruction (available on plant)	<input type="checkbox"/>	<input type="checkbox"/>	Log book	<input type="checkbox"/>	<input type="checkbox"/>	SWL / crane chart	<p>Verify Check Warning devices</p> <table style="width: 100%; border-collapse: collapse;"> <tr><td style="width: 20px;"><input type="checkbox"/></td><td style="width: 20px;"><input type="checkbox"/></td><td>Horn</td></tr> <tr><td><input type="checkbox"/></td><td><input type="checkbox"/></td><td>Amber flashing beacon</td></tr> <tr><td><input type="checkbox"/></td><td><input type="checkbox"/></td><td>Reversing alarm</td></tr> </table> <p>Verify Check Warning signs (in cabin)</p> <table style="width: 100%; border-collapse: collapse;"> <tr><td style="width: 20px;"><input type="checkbox"/></td><td style="width: 20px;"><input type="checkbox"/></td><td style="border: 1px solid black; padding: 2px; text-align: center;">SEAT BELTS MUST BE WORN</td></tr> <tr><td><input type="checkbox"/></td><td><input type="checkbox"/></td><td style="border: 1px solid black; padding: 2px; text-align: center;">DANGER – BEWARE OVERHEAD WIRES, PIPES and SERVICES</td></tr> </table>	<input type="checkbox"/>	<input type="checkbox"/>	Horn	<input type="checkbox"/>	<input type="checkbox"/>	Amber flashing beacon	<input type="checkbox"/>	<input type="checkbox"/>	Reversing alarm	<input type="checkbox"/>	<input type="checkbox"/>	SEAT BELTS MUST BE WORN	<input type="checkbox"/>	<input type="checkbox"/>	DANGER – BEWARE OVERHEAD WIRES, PIPES and SERVICES																																																								
<input type="checkbox"/>	<input type="checkbox"/>	Pivots																																																																																																																				
<input type="checkbox"/>	<input type="checkbox"/>	Connecting rods																																																																																																																				
<input type="checkbox"/>	<input type="checkbox"/>	Safety pins (no excessive wear)																																																																																																																				
<input type="checkbox"/>	<input type="checkbox"/>	Cleanliness																																																																																																																				
<input type="checkbox"/>	<input type="checkbox"/>	Seat condition OK																																																																																																																				
<input type="checkbox"/>	<input type="checkbox"/>	Operator restraint provided																																																																																																																				
<input type="checkbox"/>	<input type="checkbox"/>	Instruments operational & labeled																																																																																																																				
<input type="checkbox"/>	<input type="checkbox"/>	Levers / controls operational																																																																																																																				
<input type="checkbox"/>	<input type="checkbox"/>	Pedals in good condition																																																																																																																				
<input type="checkbox"/>	<input type="checkbox"/>	ROPS to AS 2294																																																																																																																				
<input type="checkbox"/>	<input type="checkbox"/>	Windows / wipers / washers																																																																																																																				
<input type="checkbox"/>	<input type="checkbox"/>	Rear view mirrors																																																																																																																				
<input type="checkbox"/>	<input type="checkbox"/>	Operator instruction (available on plant)																																																																																																																				
<input type="checkbox"/>	<input type="checkbox"/>	Log book																																																																																																																				
<input type="checkbox"/>	<input type="checkbox"/>	SWL / crane chart																																																																																																																				
<input type="checkbox"/>	<input type="checkbox"/>	Horn																																																																																																																				
<input type="checkbox"/>	<input type="checkbox"/>	Amber flashing beacon																																																																																																																				
<input type="checkbox"/>	<input type="checkbox"/>	Reversing alarm																																																																																																																				
<input type="checkbox"/>	<input type="checkbox"/>	SEAT BELTS MUST BE WORN																																																																																																																				
<input type="checkbox"/>	<input type="checkbox"/>	DANGER – BEWARE OVERHEAD WIRES, PIPES and SERVICES																																																																																																																				
<p>Verify Check</p> <table style="width: 100%; border-collapse: collapse;"> <tr><td style="width: 20px;"><input type="checkbox"/></td><td style="width: 20px;"><input type="checkbox"/></td><td>Hambone & wedge</td></tr> </table>	<input type="checkbox"/>	<input type="checkbox"/>	Hambone & wedge	<p>Verify Check Hydraulics</p> <table style="width: 100%; border-collapse: collapse;"> <tr><td style="width: 20px;"><input type="checkbox"/></td><td style="width: 20px;"><input type="checkbox"/></td><td>Rams</td></tr> <tr><td><input type="checkbox"/></td><td><input type="checkbox"/></td><td>Hoses</td></tr> <tr><td><input type="checkbox"/></td><td><input type="checkbox"/></td><td>Connections (check for excessive wear, leaks and creep)</td></tr> </table>	<input type="checkbox"/>	<input type="checkbox"/>	Rams	<input type="checkbox"/>	<input type="checkbox"/>	Hoses	<input type="checkbox"/>	<input type="checkbox"/>	Connections (check for excessive wear, leaks and creep)	<p>Verify Check</p> <table style="width: 100%; border-collapse: collapse;"> <tr><td style="width: 20px;"><input type="checkbox"/></td><td style="width: 20px;"><input type="checkbox"/></td><td>Tyres</td></tr> <tr><td><input type="checkbox"/></td><td><input type="checkbox"/></td><td>Wheels</td></tr> <tr><td><input type="checkbox"/></td><td><input type="checkbox"/></td><td>Brakes</td></tr> <tr><td><input type="checkbox"/></td><td><input type="checkbox"/></td><td>Park brake</td></tr> </table>	<input type="checkbox"/>	<input type="checkbox"/>	Tyres	<input type="checkbox"/>	<input type="checkbox"/>	Wheels	<input type="checkbox"/>	<input type="checkbox"/>	Brakes	<input type="checkbox"/>	<input type="checkbox"/>	Park brake																																																																																												
<input type="checkbox"/>	<input type="checkbox"/>	Hambone & wedge																																																																																																																				
<input type="checkbox"/>	<input type="checkbox"/>	Rams																																																																																																																				
<input type="checkbox"/>	<input type="checkbox"/>	Hoses																																																																																																																				
<input type="checkbox"/>	<input type="checkbox"/>	Connections (check for excessive wear, leaks and creep)																																																																																																																				
<input type="checkbox"/>	<input type="checkbox"/>	Tyres																																																																																																																				
<input type="checkbox"/>	<input type="checkbox"/>	Wheels																																																																																																																				
<input type="checkbox"/>	<input type="checkbox"/>	Brakes																																																																																																																				
<input type="checkbox"/>	<input type="checkbox"/>	Park brake																																																																																																																				
<p>Verify Check</p> <table style="width: 100%; border-collapse: collapse;"> <tr><td style="width: 20px;"><input type="checkbox"/></td><td style="width: 20px;"><input type="checkbox"/></td><td>Slings / ropes / chains (tagged and in good working order)</td></tr> <tr><td><input type="checkbox"/></td><td><input type="checkbox"/></td><td>Electrical wiring (no visual signs of damage)</td></tr> <tr><td><input type="checkbox"/></td><td><input type="checkbox"/></td><td>Steel or timber pads</td></tr> </table>	<input type="checkbox"/>	<input type="checkbox"/>	Slings / ropes / chains (tagged and in good working order)	<input type="checkbox"/>	<input type="checkbox"/>	Electrical wiring (no visual signs of damage)	<input type="checkbox"/>	<input type="checkbox"/>	Steel or timber pads	<p>Verify Check</p> <table style="width: 100%; border-collapse: collapse;"> <tr><td style="width: 20px;"><input type="checkbox"/></td><td style="width: 20px;"><input type="checkbox"/></td><td>Handrails</td></tr> <tr><td><input type="checkbox"/></td><td><input type="checkbox"/></td><td>Steps</td></tr> </table>	<input type="checkbox"/>	<input type="checkbox"/>	Handrails	<input type="checkbox"/>	<input type="checkbox"/>	Steps	<p>Verify Check</p> <table style="width: 100%; border-collapse: collapse;"> <tr><td style="width: 20px;"><input type="checkbox"/></td><td style="width: 20px;"><input type="checkbox"/></td><td>Engine guarding</td></tr> <tr><td><input type="checkbox"/></td><td><input type="checkbox"/></td><td>Exhaust</td></tr> <tr><td><input type="checkbox"/></td><td><input type="checkbox"/></td><td>Slew radius / barricading for around outriggers</td></tr> </table>	<input type="checkbox"/>	<input type="checkbox"/>	Engine guarding	<input type="checkbox"/>	<input type="checkbox"/>	Exhaust	<input type="checkbox"/>	<input type="checkbox"/>	Slew radius / barricading for around outriggers																																																																																												
<input type="checkbox"/>	<input type="checkbox"/>	Slings / ropes / chains (tagged and in good working order)																																																																																																																				
<input type="checkbox"/>	<input type="checkbox"/>	Electrical wiring (no visual signs of damage)																																																																																																																				
<input type="checkbox"/>	<input type="checkbox"/>	Steel or timber pads																																																																																																																				
<input type="checkbox"/>	<input type="checkbox"/>	Handrails																																																																																																																				
<input type="checkbox"/>	<input type="checkbox"/>	Steps																																																																																																																				
<input type="checkbox"/>	<input type="checkbox"/>	Engine guarding																																																																																																																				
<input type="checkbox"/>	<input type="checkbox"/>	Exhaust																																																																																																																				
<input type="checkbox"/>	<input type="checkbox"/>	Slew radius / barricading for around outriggers																																																																																																																				
<p>Manildra use only</p> <p>NOTE: Sign only when all items have been checked</p> <p>Plant check by: _____</p> <p>Position: _____</p> <p>Date: _____ / _____ / _____</p>																																																																																																																						

13. GRADER

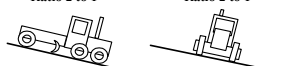
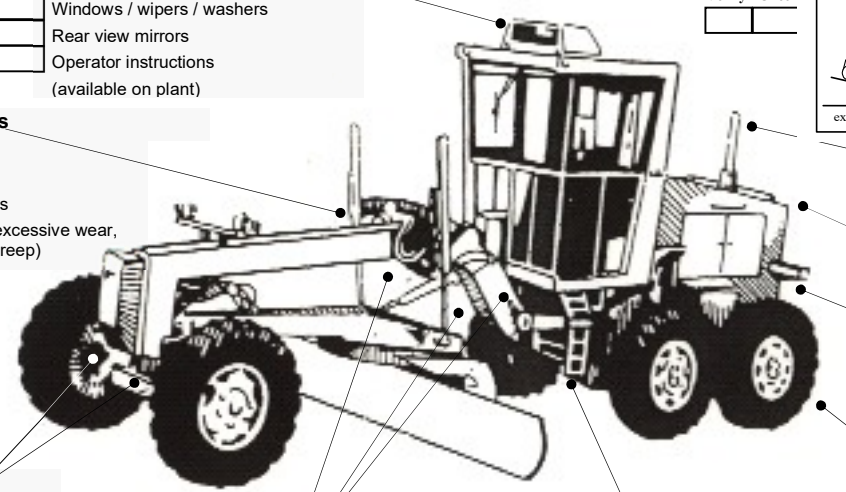
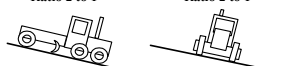
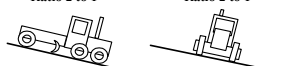
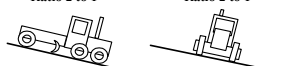
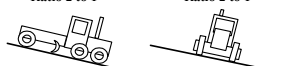
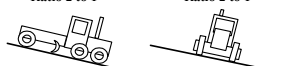
<p>Supplier verification & Plant details</p> <p>Plant owner: _____</p> <p>Address: _____</p> <p>City/Suburb: _____</p> <p>Phone: _____</p> <p>Plant make: _____</p> <p>Plant model: _____</p> <p>Serial no.: _____</p> <p>Signature: _____</p> <p>Date: _____</p> <p>Statement of operator competence required</p>	<table style="width: 100%; border-collapse: collapse;"> <tr> <td style="width: 30%; vertical-align: top;"> <table border="1" style="width: 100%; border-collapse: collapse;"> <thead> <tr> <th style="width: 10%;">Verify</th> <th style="width: 10%;">Check</th> <th style="width: 80%;">Cab</th> </tr> </thead> <tbody> <tr><td><input type="checkbox"/></td><td><input type="checkbox"/></td><td>Cleanliness</td></tr> <tr><td><input type="checkbox"/></td><td><input type="checkbox"/></td><td>Seat condition OK</td></tr> <tr><td><input type="checkbox"/></td><td><input type="checkbox"/></td><td>Operator restraint provided</td></tr> <tr><td><input type="checkbox"/></td><td><input type="checkbox"/></td><td>Instruments operational & labeled</td></tr> <tr><td><input type="checkbox"/></td><td><input type="checkbox"/></td><td>Levers / controls operational</td></tr> <tr><td><input type="checkbox"/></td><td><input type="checkbox"/></td><td>Pedals in good condition</td></tr> <tr><td><input type="checkbox"/></td><td><input type="checkbox"/></td><td>ROPS to AS 2294</td></tr> <tr><td><input type="checkbox"/></td><td><input type="checkbox"/></td><td>Windows / wipers / washers</td></tr> <tr><td><input type="checkbox"/></td><td><input type="checkbox"/></td><td>Rear view mirrors</td></tr> <tr><td><input type="checkbox"/></td><td><input type="checkbox"/></td><td>Operator instructions (available on plant)</td></tr> </tbody> </table> </td> <td style="width: 40%; vertical-align: top;"> <table border="1" style="width: 100%; border-collapse: collapse;"> <thead> <tr> <th style="width: 10%;">Verify</th> <th style="width: 10%;">Check</th> <th style="width: 80%;">Warning devices</th> </tr> </thead> <tbody> <tr><td><input type="checkbox"/></td><td><input type="checkbox"/></td><td>Horn</td></tr> <tr><td><input type="checkbox"/></td><td><input type="checkbox"/></td><td>Amber flashing beacon <12t</td></tr> <tr><td><input type="checkbox"/></td><td><input type="checkbox"/></td><td>Reversing alarm</td></tr> </tbody> </table> <table border="1" style="width: 100%; border-collapse: collapse;"> <thead> <tr> <th style="width: 10%;">Verify</th> <th style="width: 10%;">Check</th> <th style="width: 80%;">Warning signs (in cabin)</th> </tr> </thead> <tbody> <tr> <td><input type="checkbox"/></td> <td><input type="checkbox"/></td> <td style="text-align: center;">SEAT BELTS MUST BE WORN</td> </tr> <tr> <td><input type="checkbox"/></td> <td><input type="checkbox"/></td> <td style="text-align: center;"> SAFE WORK LIMIT ON BATTERS Ratio 2 to 1 Ratio 2 to 1  example only. As per manufacturer's specification </td> </tr> </tbody> </table> </td> </tr> <tr> <td style="vertical-align: top; padding: 5px;"> <ul style="list-style-type: none"> Plant to conform to manufacturer's specifications and Plant Regulations. Plant operator is to provide daily check sheets to Manildra on a weekly basis. Where applicable, Personal Protective Equipment must be worn. Plant Log Book detailing service history in accordance with Manufacturer's specifications should be written legibly in English. Contractor must produce proof of competence of operator, e.g., Certificate of Competence, Licence, detailed Log Book </td> <td style="vertical-align: top; padding: 5px;"> <table border="1" style="width: 100%; border-collapse: collapse;"> <thead> <tr> <th style="width: 10%;">Verify</th> <th style="width: 10%;">Check</th> <th style="width: 80%;">Hydraulics</th> </tr> </thead> <tbody> <tr><td><input type="checkbox"/></td><td><input type="checkbox"/></td><td>Rams</td></tr> <tr><td><input type="checkbox"/></td><td><input type="checkbox"/></td><td>Hoses</td></tr> <tr><td><input type="checkbox"/></td><td><input type="checkbox"/></td><td>Connections (check for excessive wear, leaks and creep)</td></tr> </tbody> </table> </td> </tr> <tr> <td style="vertical-align: top; padding: 5px;"> <p>Manildra use only</p> <p>NOTE: Sign only when all items have been checked</p> <p>Plant check by: _____</p> <p>Position: _____</p> <p>Date: / /</p> </td> <td style="vertical-align: top; padding: 5px;"> <table border="1" style="width: 100%; border-collapse: collapse;"> <thead> <tr> <th style="width: 10%;">Verify</th> <th style="width: 10%;">Check</th> <th style="width: 80%;">Steering</th> </tr> </thead> <tbody> <tr><td><input type="checkbox"/></td><td><input type="checkbox"/></td><td>Unions</td></tr> <tr><td><input type="checkbox"/></td><td><input type="checkbox"/></td><td>Rods</td></tr> <tr><td><input type="checkbox"/></td><td><input type="checkbox"/></td><td>Connections</td></tr> </tbody> </table> <table border="1" style="width: 100%; border-collapse: collapse;"> <thead> <tr> <th style="width: 10%;">Verify</th> <th style="width: 10%;">Check</th> <th style="width: 80%;">Tyres</th> </tr> </thead> <tbody> <tr><td><input type="checkbox"/></td><td><input type="checkbox"/></td><td>Wheels</td></tr> <tr><td><input type="checkbox"/></td><td><input type="checkbox"/></td><td>Brakes</td></tr> <tr><td><input type="checkbox"/></td><td><input type="checkbox"/></td><td>Park brake</td></tr> </tbody> </table> </td> </tr> </table> <div style="text-align: center; margin-top: 20px;">  </div> <p style="text-align: center; margin-top: 10px;">Note: Plant to be registered if used on public roads</p> <p style="text-align: right; margin-top: 10px;">Instructions: Verify box to be ticked by Owner / Supplier / Operator prior to arrival onsite. Check box to be ticked after visual inspection by Manildra.</p>	<table border="1" style="width: 100%; border-collapse: collapse;"> <thead> <tr> <th style="width: 10%;">Verify</th> <th style="width: 10%;">Check</th> <th style="width: 80%;">Cab</th> </tr> </thead> <tbody> <tr><td><input type="checkbox"/></td><td><input type="checkbox"/></td><td>Cleanliness</td></tr> <tr><td><input type="checkbox"/></td><td><input type="checkbox"/></td><td>Seat condition OK</td></tr> <tr><td><input type="checkbox"/></td><td><input type="checkbox"/></td><td>Operator restraint provided</td></tr> <tr><td><input type="checkbox"/></td><td><input type="checkbox"/></td><td>Instruments operational & labeled</td></tr> <tr><td><input type="checkbox"/></td><td><input type="checkbox"/></td><td>Levers / controls operational</td></tr> <tr><td><input type="checkbox"/></td><td><input type="checkbox"/></td><td>Pedals in good condition</td></tr> <tr><td><input type="checkbox"/></td><td><input type="checkbox"/></td><td>ROPS to AS 2294</td></tr> <tr><td><input type="checkbox"/></td><td><input type="checkbox"/></td><td>Windows / wipers / washers</td></tr> <tr><td><input type="checkbox"/></td><td><input type="checkbox"/></td><td>Rear view mirrors</td></tr> <tr><td><input type="checkbox"/></td><td><input type="checkbox"/></td><td>Operator instructions (available on plant)</td></tr> </tbody> </table>	Verify	Check	Cab	<input type="checkbox"/>	<input type="checkbox"/>	Cleanliness	<input type="checkbox"/>	<input type="checkbox"/>	Seat condition OK	<input type="checkbox"/>	<input type="checkbox"/>	Operator restraint provided	<input type="checkbox"/>	<input type="checkbox"/>	Instruments operational & labeled	<input type="checkbox"/>	<input type="checkbox"/>	Levers / controls operational	<input type="checkbox"/>	<input type="checkbox"/>	Pedals in good condition	<input type="checkbox"/>	<input type="checkbox"/>	ROPS to AS 2294	<input type="checkbox"/>	<input type="checkbox"/>	Windows / wipers / washers	<input type="checkbox"/>	<input type="checkbox"/>	Rear view mirrors	<input type="checkbox"/>	<input type="checkbox"/>	Operator instructions (available on plant)	<table border="1" style="width: 100%; border-collapse: collapse;"> <thead> <tr> <th style="width: 10%;">Verify</th> <th style="width: 10%;">Check</th> <th style="width: 80%;">Warning devices</th> </tr> </thead> <tbody> <tr><td><input type="checkbox"/></td><td><input type="checkbox"/></td><td>Horn</td></tr> <tr><td><input type="checkbox"/></td><td><input type="checkbox"/></td><td>Amber flashing beacon <12t</td></tr> <tr><td><input type="checkbox"/></td><td><input type="checkbox"/></td><td>Reversing alarm</td></tr> </tbody> </table> <table border="1" style="width: 100%; border-collapse: collapse;"> <thead> <tr> <th style="width: 10%;">Verify</th> <th style="width: 10%;">Check</th> <th style="width: 80%;">Warning signs (in cabin)</th> </tr> </thead> <tbody> <tr> <td><input type="checkbox"/></td> <td><input type="checkbox"/></td> <td style="text-align: center;">SEAT BELTS MUST BE WORN</td> </tr> <tr> <td><input type="checkbox"/></td> <td><input type="checkbox"/></td> <td style="text-align: center;"> SAFE WORK LIMIT ON BATTERS Ratio 2 to 1 Ratio 2 to 1  example only. As per manufacturer's specification </td> </tr> </tbody> </table>	Verify	Check	Warning devices	<input type="checkbox"/>	<input type="checkbox"/>	Horn	<input type="checkbox"/>	<input type="checkbox"/>	Amber flashing beacon <12t	<input type="checkbox"/>	<input type="checkbox"/>	Reversing alarm	Verify	Check	Warning signs (in cabin)	<input type="checkbox"/>	<input type="checkbox"/>	SEAT BELTS MUST BE WORN	<input type="checkbox"/>	<input type="checkbox"/>	SAFE WORK LIMIT ON BATTERS Ratio 2 to 1 Ratio 2 to 1  example only. As per manufacturer's specification	<ul style="list-style-type: none"> Plant to conform to manufacturer's specifications and Plant Regulations. Plant operator is to provide daily check sheets to Manildra on a weekly basis. Where applicable, Personal Protective Equipment must be worn. Plant Log Book detailing service history in accordance with Manufacturer's specifications should be written legibly in English. Contractor must produce proof of competence of operator, e.g., Certificate of Competence, Licence, detailed Log Book 	<table border="1" style="width: 100%; border-collapse: collapse;"> <thead> <tr> <th style="width: 10%;">Verify</th> <th style="width: 10%;">Check</th> <th style="width: 80%;">Hydraulics</th> </tr> </thead> <tbody> <tr><td><input type="checkbox"/></td><td><input type="checkbox"/></td><td>Rams</td></tr> <tr><td><input type="checkbox"/></td><td><input type="checkbox"/></td><td>Hoses</td></tr> <tr><td><input type="checkbox"/></td><td><input type="checkbox"/></td><td>Connections (check for excessive wear, leaks and creep)</td></tr> </tbody> </table>	Verify	Check	Hydraulics	<input type="checkbox"/>	<input type="checkbox"/>	Rams	<input type="checkbox"/>	<input type="checkbox"/>	Hoses	<input type="checkbox"/>	<input type="checkbox"/>	Connections (check for excessive wear, leaks and creep)	<p>Manildra use only</p> <p>NOTE: Sign only when all items have been checked</p> <p>Plant check by: _____</p> <p>Position: _____</p> <p>Date: / /</p>	<table border="1" style="width: 100%; border-collapse: collapse;"> <thead> <tr> <th style="width: 10%;">Verify</th> <th style="width: 10%;">Check</th> <th style="width: 80%;">Steering</th> </tr> </thead> <tbody> <tr><td><input type="checkbox"/></td><td><input type="checkbox"/></td><td>Unions</td></tr> <tr><td><input type="checkbox"/></td><td><input type="checkbox"/></td><td>Rods</td></tr> <tr><td><input type="checkbox"/></td><td><input type="checkbox"/></td><td>Connections</td></tr> </tbody> </table> <table border="1" style="width: 100%; border-collapse: collapse;"> <thead> <tr> <th style="width: 10%;">Verify</th> <th style="width: 10%;">Check</th> <th style="width: 80%;">Tyres</th> </tr> </thead> <tbody> <tr><td><input type="checkbox"/></td><td><input type="checkbox"/></td><td>Wheels</td></tr> <tr><td><input type="checkbox"/></td><td><input type="checkbox"/></td><td>Brakes</td></tr> <tr><td><input type="checkbox"/></td><td><input type="checkbox"/></td><td>Park brake</td></tr> </tbody> </table>	Verify	Check	Steering	<input type="checkbox"/>	<input type="checkbox"/>	Unions	<input type="checkbox"/>	<input type="checkbox"/>	Rods	<input type="checkbox"/>	<input type="checkbox"/>	Connections	Verify	Check	Tyres	<input type="checkbox"/>	<input type="checkbox"/>	Wheels	<input type="checkbox"/>	<input type="checkbox"/>	Brakes	<input type="checkbox"/>	<input type="checkbox"/>	Park brake
<table border="1" style="width: 100%; border-collapse: collapse;"> <thead> <tr> <th style="width: 10%;">Verify</th> <th style="width: 10%;">Check</th> <th style="width: 80%;">Cab</th> </tr> </thead> <tbody> <tr><td><input type="checkbox"/></td><td><input type="checkbox"/></td><td>Cleanliness</td></tr> <tr><td><input type="checkbox"/></td><td><input type="checkbox"/></td><td>Seat condition OK</td></tr> <tr><td><input type="checkbox"/></td><td><input type="checkbox"/></td><td>Operator restraint provided</td></tr> <tr><td><input type="checkbox"/></td><td><input type="checkbox"/></td><td>Instruments operational & labeled</td></tr> <tr><td><input type="checkbox"/></td><td><input type="checkbox"/></td><td>Levers / controls operational</td></tr> <tr><td><input type="checkbox"/></td><td><input type="checkbox"/></td><td>Pedals in good condition</td></tr> <tr><td><input type="checkbox"/></td><td><input type="checkbox"/></td><td>ROPS to AS 2294</td></tr> <tr><td><input type="checkbox"/></td><td><input type="checkbox"/></td><td>Windows / wipers / washers</td></tr> <tr><td><input type="checkbox"/></td><td><input type="checkbox"/></td><td>Rear view mirrors</td></tr> <tr><td><input type="checkbox"/></td><td><input type="checkbox"/></td><td>Operator instructions (available on plant)</td></tr> </tbody> </table>	Verify	Check	Cab	<input type="checkbox"/>	<input type="checkbox"/>	Cleanliness	<input type="checkbox"/>	<input type="checkbox"/>	Seat condition OK	<input type="checkbox"/>	<input type="checkbox"/>	Operator restraint provided	<input type="checkbox"/>	<input type="checkbox"/>	Instruments operational & labeled	<input type="checkbox"/>	<input type="checkbox"/>	Levers / controls operational	<input type="checkbox"/>	<input type="checkbox"/>	Pedals in good condition	<input type="checkbox"/>	<input type="checkbox"/>	ROPS to AS 2294	<input type="checkbox"/>	<input type="checkbox"/>	Windows / wipers / washers	<input type="checkbox"/>	<input type="checkbox"/>	Rear view mirrors	<input type="checkbox"/>	<input type="checkbox"/>	Operator instructions (available on plant)	<table border="1" style="width: 100%; border-collapse: collapse;"> <thead> <tr> <th style="width: 10%;">Verify</th> <th style="width: 10%;">Check</th> <th style="width: 80%;">Warning devices</th> </tr> </thead> <tbody> <tr><td><input type="checkbox"/></td><td><input type="checkbox"/></td><td>Horn</td></tr> <tr><td><input type="checkbox"/></td><td><input type="checkbox"/></td><td>Amber flashing beacon <12t</td></tr> <tr><td><input type="checkbox"/></td><td><input type="checkbox"/></td><td>Reversing alarm</td></tr> </tbody> </table> <table border="1" style="width: 100%; border-collapse: collapse;"> <thead> <tr> <th style="width: 10%;">Verify</th> <th style="width: 10%;">Check</th> <th style="width: 80%;">Warning signs (in cabin)</th> </tr> </thead> <tbody> <tr> <td><input type="checkbox"/></td> <td><input type="checkbox"/></td> <td style="text-align: center;">SEAT BELTS MUST BE WORN</td> </tr> <tr> <td><input type="checkbox"/></td> <td><input type="checkbox"/></td> <td style="text-align: center;"> SAFE WORK LIMIT ON BATTERS Ratio 2 to 1 Ratio 2 to 1  example only. As per manufacturer's specification </td> </tr> </tbody> </table>	Verify	Check	Warning devices	<input type="checkbox"/>	<input type="checkbox"/>	Horn	<input type="checkbox"/>	<input type="checkbox"/>	Amber flashing beacon <12t	<input type="checkbox"/>	<input type="checkbox"/>	Reversing alarm	Verify	Check	Warning signs (in cabin)	<input type="checkbox"/>	<input type="checkbox"/>	SEAT BELTS MUST BE WORN	<input type="checkbox"/>	<input type="checkbox"/>	SAFE WORK LIMIT ON BATTERS Ratio 2 to 1 Ratio 2 to 1  example only. As per manufacturer's specification																																										
Verify	Check	Cab																																																																																															
<input type="checkbox"/>	<input type="checkbox"/>	Cleanliness																																																																																															
<input type="checkbox"/>	<input type="checkbox"/>	Seat condition OK																																																																																															
<input type="checkbox"/>	<input type="checkbox"/>	Operator restraint provided																																																																																															
<input type="checkbox"/>	<input type="checkbox"/>	Instruments operational & labeled																																																																																															
<input type="checkbox"/>	<input type="checkbox"/>	Levers / controls operational																																																																																															
<input type="checkbox"/>	<input type="checkbox"/>	Pedals in good condition																																																																																															
<input type="checkbox"/>	<input type="checkbox"/>	ROPS to AS 2294																																																																																															
<input type="checkbox"/>	<input type="checkbox"/>	Windows / wipers / washers																																																																																															
<input type="checkbox"/>	<input type="checkbox"/>	Rear view mirrors																																																																																															
<input type="checkbox"/>	<input type="checkbox"/>	Operator instructions (available on plant)																																																																																															
Verify	Check	Warning devices																																																																																															
<input type="checkbox"/>	<input type="checkbox"/>	Horn																																																																																															
<input type="checkbox"/>	<input type="checkbox"/>	Amber flashing beacon <12t																																																																																															
<input type="checkbox"/>	<input type="checkbox"/>	Reversing alarm																																																																																															
Verify	Check	Warning signs (in cabin)																																																																																															
<input type="checkbox"/>	<input type="checkbox"/>	SEAT BELTS MUST BE WORN																																																																																															
<input type="checkbox"/>	<input type="checkbox"/>	SAFE WORK LIMIT ON BATTERS Ratio 2 to 1 Ratio 2 to 1  example only. As per manufacturer's specification																																																																																															
<ul style="list-style-type: none"> Plant to conform to manufacturer's specifications and Plant Regulations. Plant operator is to provide daily check sheets to Manildra on a weekly basis. Where applicable, Personal Protective Equipment must be worn. Plant Log Book detailing service history in accordance with Manufacturer's specifications should be written legibly in English. Contractor must produce proof of competence of operator, e.g., Certificate of Competence, Licence, detailed Log Book 	<table border="1" style="width: 100%; border-collapse: collapse;"> <thead> <tr> <th style="width: 10%;">Verify</th> <th style="width: 10%;">Check</th> <th style="width: 80%;">Hydraulics</th> </tr> </thead> <tbody> <tr><td><input type="checkbox"/></td><td><input type="checkbox"/></td><td>Rams</td></tr> <tr><td><input type="checkbox"/></td><td><input type="checkbox"/></td><td>Hoses</td></tr> <tr><td><input type="checkbox"/></td><td><input type="checkbox"/></td><td>Connections (check for excessive wear, leaks and creep)</td></tr> </tbody> </table>	Verify	Check	Hydraulics	<input type="checkbox"/>	<input type="checkbox"/>	Rams	<input type="checkbox"/>	<input type="checkbox"/>	Hoses	<input type="checkbox"/>	<input type="checkbox"/>	Connections (check for excessive wear, leaks and creep)																																																																																				
Verify	Check	Hydraulics																																																																																															
<input type="checkbox"/>	<input type="checkbox"/>	Rams																																																																																															
<input type="checkbox"/>	<input type="checkbox"/>	Hoses																																																																																															
<input type="checkbox"/>	<input type="checkbox"/>	Connections (check for excessive wear, leaks and creep)																																																																																															
<p>Manildra use only</p> <p>NOTE: Sign only when all items have been checked</p> <p>Plant check by: _____</p> <p>Position: _____</p> <p>Date: / /</p>	<table border="1" style="width: 100%; border-collapse: collapse;"> <thead> <tr> <th style="width: 10%;">Verify</th> <th style="width: 10%;">Check</th> <th style="width: 80%;">Steering</th> </tr> </thead> <tbody> <tr><td><input type="checkbox"/></td><td><input type="checkbox"/></td><td>Unions</td></tr> <tr><td><input type="checkbox"/></td><td><input type="checkbox"/></td><td>Rods</td></tr> <tr><td><input type="checkbox"/></td><td><input type="checkbox"/></td><td>Connections</td></tr> </tbody> </table> <table border="1" style="width: 100%; border-collapse: collapse;"> <thead> <tr> <th style="width: 10%;">Verify</th> <th style="width: 10%;">Check</th> <th style="width: 80%;">Tyres</th> </tr> </thead> <tbody> <tr><td><input type="checkbox"/></td><td><input type="checkbox"/></td><td>Wheels</td></tr> <tr><td><input type="checkbox"/></td><td><input type="checkbox"/></td><td>Brakes</td></tr> <tr><td><input type="checkbox"/></td><td><input type="checkbox"/></td><td>Park brake</td></tr> </tbody> </table>	Verify	Check	Steering	<input type="checkbox"/>	<input type="checkbox"/>	Unions	<input type="checkbox"/>	<input type="checkbox"/>	Rods	<input type="checkbox"/>	<input type="checkbox"/>	Connections	Verify	Check	Tyres	<input type="checkbox"/>	<input type="checkbox"/>	Wheels	<input type="checkbox"/>	<input type="checkbox"/>	Brakes	<input type="checkbox"/>	<input type="checkbox"/>	Park brake																																																																								
Verify	Check	Steering																																																																																															
<input type="checkbox"/>	<input type="checkbox"/>	Unions																																																																																															
<input type="checkbox"/>	<input type="checkbox"/>	Rods																																																																																															
<input type="checkbox"/>	<input type="checkbox"/>	Connections																																																																																															
Verify	Check	Tyres																																																																																															
<input type="checkbox"/>	<input type="checkbox"/>	Wheels																																																																																															
<input type="checkbox"/>	<input type="checkbox"/>	Brakes																																																																																															
<input type="checkbox"/>	<input type="checkbox"/>	Park brake																																																																																															

MANILDRA GROUP - Procedure for inspecting incoming mobile plant

14. FORK

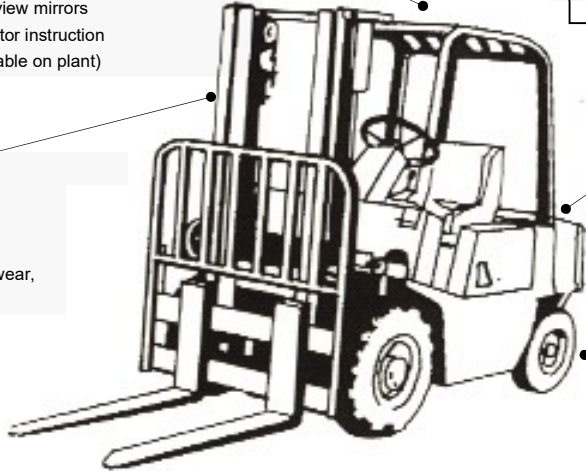
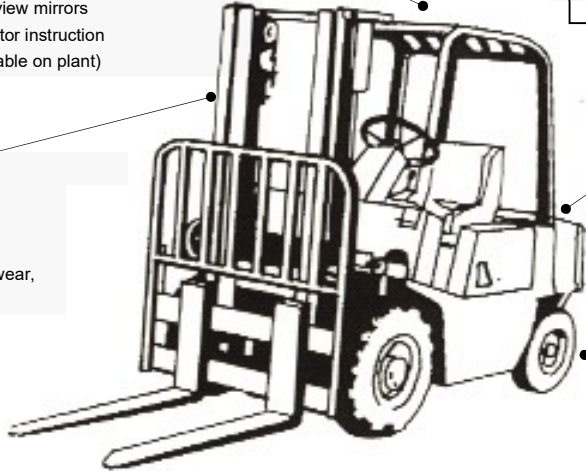
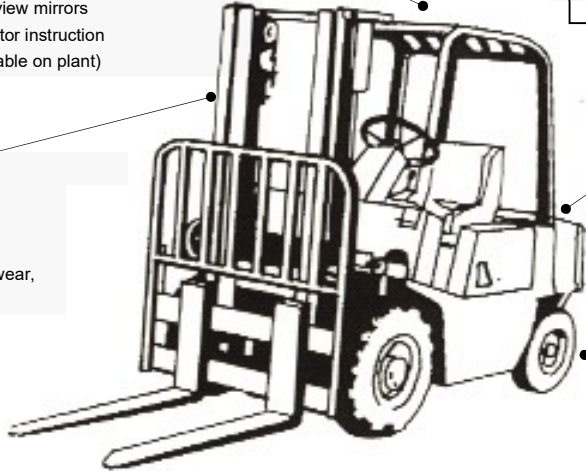
<p>Supplier verification & Plant details</p> <p>Plant owner: _____</p> <p>Address: _____</p> <p>City/Suburb: _____</p> <p>Phone: _____</p> <p>Plant make: _____</p> <p>Plant model: _____</p> <p>Serial no.: _____</p> <p>Signature: _____</p> <p>Date: _____</p> <p>SafeWork Certification - LF</p>	<table style="width: 100%; border-collapse: collapse;"> <tr> <td style="width: 30%; vertical-align: top;"> <table border="1" style="width: 100%; border-collapse: collapse;"> <thead> <tr> <th style="width: 50px;">Verify</th> <th>Check</th> </tr> </thead> <tbody> <tr><td><input type="checkbox"/></td><td>Cleanliness</td></tr> <tr><td><input type="checkbox"/></td><td>Seat condition OK</td></tr> <tr><td><input type="checkbox"/></td><td>Operator restraint provided</td></tr> <tr><td><input type="checkbox"/></td><td>Instruments operational & labelled</td></tr> <tr><td><input type="checkbox"/></td><td>Levers / controls operational</td></tr> <tr><td><input type="checkbox"/></td><td>Pedals in good condition</td></tr> <tr><td><input type="checkbox"/></td><td>ROPS to AS 2294</td></tr> <tr><td><input type="checkbox"/></td><td>Windows / wipers / washers</td></tr> <tr><td><input type="checkbox"/></td><td>Rear view mirrors</td></tr> <tr><td><input type="checkbox"/></td><td>Operator instruction (Available on plant)</td></tr> </tbody> </table> </td> <td style="width: 40%; text-align: center; vertical-align: middle;">  </td> <td style="width: 30%; vertical-align: top;"> <table style="width: 100%; border-collapse: collapse;"> <tr> <td style="width: 50px;">Verify</td> <td>Check</td> <td style="width: 50px;"></td> <td></td> </tr> <tr> <td><input type="checkbox"/></td> <td></td> <td><input type="checkbox"/></td> <td>Horn</td> </tr> <tr> <td><input type="checkbox"/></td> <td></td> <td><input type="checkbox"/></td> <td>Amber flashing beacon</td> </tr> <tr> <td><input type="checkbox"/></td> <td></td> <td><input type="checkbox"/></td> <td>Reversing alarm</td> </tr> </table> <table style="width: 100%; border-collapse: collapse;"> <tr> <td style="width: 50px;">Verify</td> <td>Check</td> <td style="width: 50px;"></td> <td></td> </tr> <tr> <td><input type="checkbox"/></td> <td><input type="checkbox"/></td> <td colspan="2" style="border: 1px solid black; text-align: center; padding: 2px;">SEAT BELTS MUST BE WORN</td> </tr> </table> <table style="width: 100%; border-collapse: collapse;"> <tr> <td style="width: 50px;">Verify</td> <td>Check</td> <td style="width: 50px;"></td> <td></td> </tr> <tr> <td><input type="checkbox"/></td> <td><input type="checkbox"/></td> <td colspan="2" style="border: 1px solid black; text-align: center; padding: 2px;">DANGER – BEWARE OVERHEAD WIRES, PIPES and SERVICES</td> </tr> </table> <table style="width: 100%; border-collapse: collapse;"> <tr> <td style="width: 50px;">Verify</td> <td>Check</td> <td style="width: 50px;"></td> <td></td> </tr> <tr> <td><input type="checkbox"/></td> <td></td> <td><input type="checkbox"/></td> <td>Exhaust</td> </tr> </table> <table style="width: 100%; border-collapse: collapse;"> <tr> <td style="width: 50px;">Verify</td> <td>Check</td> <td style="width: 50px;"></td> <td></td> </tr> <tr> <td><input type="checkbox"/></td> <td></td> <td><input type="checkbox"/></td> <td>Engine guarding</td> </tr> </table> <table style="width: 100%; border-collapse: collapse;"> <tr> <td style="width: 50px;">Verify</td> <td>Check</td> <td style="width: 50px;"></td> <td></td> </tr> <tr> <td><input type="checkbox"/></td> <td></td> <td><input type="checkbox"/></td> <td>Unions</td> </tr> <tr> <td><input type="checkbox"/></td> <td></td> <td><input type="checkbox"/></td> <td>Rods</td> </tr> <tr> <td><input type="checkbox"/></td> <td></td> <td><input type="checkbox"/></td> <td>Connections</td> </tr> </table> </td> </tr> </table>	<table border="1" style="width: 100%; border-collapse: collapse;"> <thead> <tr> <th style="width: 50px;">Verify</th> <th>Check</th> </tr> </thead> <tbody> <tr><td><input type="checkbox"/></td><td>Cleanliness</td></tr> <tr><td><input type="checkbox"/></td><td>Seat condition OK</td></tr> <tr><td><input type="checkbox"/></td><td>Operator restraint provided</td></tr> <tr><td><input type="checkbox"/></td><td>Instruments operational & labelled</td></tr> <tr><td><input type="checkbox"/></td><td>Levers / controls operational</td></tr> <tr><td><input type="checkbox"/></td><td>Pedals in good condition</td></tr> <tr><td><input type="checkbox"/></td><td>ROPS to AS 2294</td></tr> <tr><td><input type="checkbox"/></td><td>Windows / wipers / washers</td></tr> <tr><td><input type="checkbox"/></td><td>Rear view mirrors</td></tr> <tr><td><input type="checkbox"/></td><td>Operator instruction (Available on plant)</td></tr> </tbody> </table>	Verify	Check	<input type="checkbox"/>	Cleanliness	<input type="checkbox"/>	Seat condition OK	<input type="checkbox"/>	Operator restraint provided	<input type="checkbox"/>	Instruments operational & labelled	<input type="checkbox"/>	Levers / controls operational	<input type="checkbox"/>	Pedals in good condition	<input type="checkbox"/>	ROPS to AS 2294	<input type="checkbox"/>	Windows / wipers / washers	<input type="checkbox"/>	Rear view mirrors	<input type="checkbox"/>	Operator instruction (Available on plant)		<table style="width: 100%; border-collapse: collapse;"> <tr> <td style="width: 50px;">Verify</td> <td>Check</td> <td style="width: 50px;"></td> <td></td> </tr> <tr> <td><input type="checkbox"/></td> <td></td> <td><input type="checkbox"/></td> <td>Horn</td> </tr> <tr> <td><input type="checkbox"/></td> <td></td> <td><input type="checkbox"/></td> <td>Amber flashing beacon</td> </tr> <tr> <td><input type="checkbox"/></td> <td></td> <td><input type="checkbox"/></td> <td>Reversing alarm</td> </tr> </table> <table style="width: 100%; border-collapse: collapse;"> <tr> <td style="width: 50px;">Verify</td> <td>Check</td> <td style="width: 50px;"></td> <td></td> </tr> <tr> <td><input type="checkbox"/></td> <td><input type="checkbox"/></td> <td colspan="2" style="border: 1px solid black; text-align: center; padding: 2px;">SEAT BELTS MUST BE WORN</td> </tr> </table> <table style="width: 100%; border-collapse: collapse;"> <tr> <td style="width: 50px;">Verify</td> <td>Check</td> <td style="width: 50px;"></td> <td></td> </tr> <tr> <td><input type="checkbox"/></td> <td><input type="checkbox"/></td> <td colspan="2" style="border: 1px solid black; text-align: center; padding: 2px;">DANGER – BEWARE OVERHEAD WIRES, PIPES and SERVICES</td> </tr> </table> <table style="width: 100%; border-collapse: collapse;"> <tr> <td style="width: 50px;">Verify</td> <td>Check</td> <td style="width: 50px;"></td> <td></td> </tr> <tr> <td><input type="checkbox"/></td> <td></td> <td><input type="checkbox"/></td> <td>Exhaust</td> </tr> </table> <table style="width: 100%; border-collapse: collapse;"> <tr> <td style="width: 50px;">Verify</td> <td>Check</td> <td style="width: 50px;"></td> <td></td> </tr> <tr> <td><input type="checkbox"/></td> <td></td> <td><input type="checkbox"/></td> <td>Engine guarding</td> </tr> </table> <table style="width: 100%; border-collapse: collapse;"> <tr> <td style="width: 50px;">Verify</td> <td>Check</td> <td style="width: 50px;"></td> <td></td> </tr> <tr> <td><input type="checkbox"/></td> <td></td> <td><input type="checkbox"/></td> <td>Unions</td> </tr> <tr> <td><input type="checkbox"/></td> <td></td> <td><input type="checkbox"/></td> <td>Rods</td> </tr> <tr> <td><input type="checkbox"/></td> <td></td> <td><input type="checkbox"/></td> <td>Connections</td> </tr> </table>	Verify	Check			<input type="checkbox"/>		<input type="checkbox"/>	Horn	<input type="checkbox"/>		<input type="checkbox"/>	Amber flashing beacon	<input type="checkbox"/>		<input type="checkbox"/>	Reversing alarm	Verify	Check			<input type="checkbox"/>	<input type="checkbox"/>	SEAT BELTS MUST BE WORN		Verify	Check			<input type="checkbox"/>	<input type="checkbox"/>	DANGER – BEWARE OVERHEAD WIRES, PIPES and SERVICES		Verify	Check			<input type="checkbox"/>		<input type="checkbox"/>	Exhaust	Verify	Check			<input type="checkbox"/>		<input type="checkbox"/>	Engine guarding	Verify	Check			<input type="checkbox"/>		<input type="checkbox"/>	Unions	<input type="checkbox"/>		<input type="checkbox"/>	Rods	<input type="checkbox"/>		<input type="checkbox"/>	Connections
<table border="1" style="width: 100%; border-collapse: collapse;"> <thead> <tr> <th style="width: 50px;">Verify</th> <th>Check</th> </tr> </thead> <tbody> <tr><td><input type="checkbox"/></td><td>Cleanliness</td></tr> <tr><td><input type="checkbox"/></td><td>Seat condition OK</td></tr> <tr><td><input type="checkbox"/></td><td>Operator restraint provided</td></tr> <tr><td><input type="checkbox"/></td><td>Instruments operational & labelled</td></tr> <tr><td><input type="checkbox"/></td><td>Levers / controls operational</td></tr> <tr><td><input type="checkbox"/></td><td>Pedals in good condition</td></tr> <tr><td><input type="checkbox"/></td><td>ROPS to AS 2294</td></tr> <tr><td><input type="checkbox"/></td><td>Windows / wipers / washers</td></tr> <tr><td><input type="checkbox"/></td><td>Rear view mirrors</td></tr> <tr><td><input type="checkbox"/></td><td>Operator instruction (Available on plant)</td></tr> </tbody> </table>	Verify	Check	<input type="checkbox"/>	Cleanliness	<input type="checkbox"/>	Seat condition OK	<input type="checkbox"/>	Operator restraint provided	<input type="checkbox"/>	Instruments operational & labelled	<input type="checkbox"/>	Levers / controls operational	<input type="checkbox"/>	Pedals in good condition	<input type="checkbox"/>	ROPS to AS 2294	<input type="checkbox"/>	Windows / wipers / washers	<input type="checkbox"/>	Rear view mirrors	<input type="checkbox"/>	Operator instruction (Available on plant)		<table style="width: 100%; border-collapse: collapse;"> <tr> <td style="width: 50px;">Verify</td> <td>Check</td> <td style="width: 50px;"></td> <td></td> </tr> <tr> <td><input type="checkbox"/></td> <td></td> <td><input type="checkbox"/></td> <td>Horn</td> </tr> <tr> <td><input type="checkbox"/></td> <td></td> <td><input type="checkbox"/></td> <td>Amber flashing beacon</td> </tr> <tr> <td><input type="checkbox"/></td> <td></td> <td><input type="checkbox"/></td> <td>Reversing alarm</td> </tr> </table> <table style="width: 100%; border-collapse: collapse;"> <tr> <td style="width: 50px;">Verify</td> <td>Check</td> <td style="width: 50px;"></td> <td></td> </tr> <tr> <td><input type="checkbox"/></td> <td><input type="checkbox"/></td> <td colspan="2" style="border: 1px solid black; text-align: center; padding: 2px;">SEAT BELTS MUST BE WORN</td> </tr> </table> <table style="width: 100%; border-collapse: collapse;"> <tr> <td style="width: 50px;">Verify</td> <td>Check</td> <td style="width: 50px;"></td> <td></td> </tr> <tr> <td><input type="checkbox"/></td> <td><input type="checkbox"/></td> <td colspan="2" style="border: 1px solid black; text-align: center; padding: 2px;">DANGER – BEWARE OVERHEAD WIRES, PIPES and SERVICES</td> </tr> </table> <table style="width: 100%; border-collapse: collapse;"> <tr> <td style="width: 50px;">Verify</td> <td>Check</td> <td style="width: 50px;"></td> <td></td> </tr> <tr> <td><input type="checkbox"/></td> <td></td> <td><input type="checkbox"/></td> <td>Exhaust</td> </tr> </table> <table style="width: 100%; border-collapse: collapse;"> <tr> <td style="width: 50px;">Verify</td> <td>Check</td> <td style="width: 50px;"></td> <td></td> </tr> <tr> <td><input type="checkbox"/></td> <td></td> <td><input type="checkbox"/></td> <td>Engine guarding</td> </tr> </table> <table style="width: 100%; border-collapse: collapse;"> <tr> <td style="width: 50px;">Verify</td> <td>Check</td> <td style="width: 50px;"></td> <td></td> </tr> <tr> <td><input type="checkbox"/></td> <td></td> <td><input type="checkbox"/></td> <td>Unions</td> </tr> <tr> <td><input type="checkbox"/></td> <td></td> <td><input type="checkbox"/></td> <td>Rods</td> </tr> <tr> <td><input type="checkbox"/></td> <td></td> <td><input type="checkbox"/></td> <td>Connections</td> </tr> </table>	Verify	Check			<input type="checkbox"/>		<input type="checkbox"/>	Horn	<input type="checkbox"/>		<input type="checkbox"/>	Amber flashing beacon	<input type="checkbox"/>		<input type="checkbox"/>	Reversing alarm	Verify	Check			<input type="checkbox"/>	<input type="checkbox"/>	SEAT BELTS MUST BE WORN		Verify	Check			<input type="checkbox"/>	<input type="checkbox"/>	DANGER – BEWARE OVERHEAD WIRES, PIPES and SERVICES		Verify	Check			<input type="checkbox"/>		<input type="checkbox"/>	Exhaust	Verify	Check			<input type="checkbox"/>		<input type="checkbox"/>	Engine guarding	Verify	Check			<input type="checkbox"/>		<input type="checkbox"/>	Unions	<input type="checkbox"/>		<input type="checkbox"/>	Rods	<input type="checkbox"/>		<input type="checkbox"/>	Connections		
Verify	Check																																																																																									
<input type="checkbox"/>	Cleanliness																																																																																									
<input type="checkbox"/>	Seat condition OK																																																																																									
<input type="checkbox"/>	Operator restraint provided																																																																																									
<input type="checkbox"/>	Instruments operational & labelled																																																																																									
<input type="checkbox"/>	Levers / controls operational																																																																																									
<input type="checkbox"/>	Pedals in good condition																																																																																									
<input type="checkbox"/>	ROPS to AS 2294																																																																																									
<input type="checkbox"/>	Windows / wipers / washers																																																																																									
<input type="checkbox"/>	Rear view mirrors																																																																																									
<input type="checkbox"/>	Operator instruction (Available on plant)																																																																																									
Verify	Check																																																																																									
<input type="checkbox"/>		<input type="checkbox"/>	Horn																																																																																							
<input type="checkbox"/>		<input type="checkbox"/>	Amber flashing beacon																																																																																							
<input type="checkbox"/>		<input type="checkbox"/>	Reversing alarm																																																																																							
Verify	Check																																																																																									
<input type="checkbox"/>	<input type="checkbox"/>	SEAT BELTS MUST BE WORN																																																																																								
Verify	Check																																																																																									
<input type="checkbox"/>	<input type="checkbox"/>	DANGER – BEWARE OVERHEAD WIRES, PIPES and SERVICES																																																																																								
Verify	Check																																																																																									
<input type="checkbox"/>		<input type="checkbox"/>	Exhaust																																																																																							
Verify	Check																																																																																									
<input type="checkbox"/>		<input type="checkbox"/>	Engine guarding																																																																																							
Verify	Check																																																																																									
<input type="checkbox"/>		<input type="checkbox"/>	Unions																																																																																							
<input type="checkbox"/>		<input type="checkbox"/>	Rods																																																																																							
<input type="checkbox"/>		<input type="checkbox"/>	Connections																																																																																							
<ul style="list-style-type: none"> Plant to conform to manufacturer's specifications and Plant Regulations. Plant Operator is to provide daily check sheets to Manildra on a weekly basis. Where applicable, Personal Protective Equipment must be worn. Plant Log Book detailing service history in accordance with Manufacturer's specifications should be written legibly in English. Contractor must produce proof of competence of operator, e.g., Certificate of Competence, Licence, detailed Log Book. 	<table style="width: 100%; border-collapse: collapse;"> <tr> <td style="width: 30%; vertical-align: top;"> <table border="1" style="width: 100%; border-collapse: collapse;"> <thead> <tr> <th style="width: 50px;">Verify</th> <th>Check</th> </tr> </thead> <tbody> <tr><td><input type="checkbox"/></td><td>Rams</td></tr> <tr><td><input type="checkbox"/></td><td>Hoses</td></tr> <tr><td><input type="checkbox"/></td><td>Connections (check for excessive wear, leaks and creep)</td></tr> </tbody> </table> </td> <td style="width: 40%;"></td> <td style="width: 30%;"></td> </tr> </table>	<table border="1" style="width: 100%; border-collapse: collapse;"> <thead> <tr> <th style="width: 50px;">Verify</th> <th>Check</th> </tr> </thead> <tbody> <tr><td><input type="checkbox"/></td><td>Rams</td></tr> <tr><td><input type="checkbox"/></td><td>Hoses</td></tr> <tr><td><input type="checkbox"/></td><td>Connections (check for excessive wear, leaks and creep)</td></tr> </tbody> </table>	Verify	Check	<input type="checkbox"/>	Rams	<input type="checkbox"/>	Hoses	<input type="checkbox"/>	Connections (check for excessive wear, leaks and creep)																																																																																
<table border="1" style="width: 100%; border-collapse: collapse;"> <thead> <tr> <th style="width: 50px;">Verify</th> <th>Check</th> </tr> </thead> <tbody> <tr><td><input type="checkbox"/></td><td>Rams</td></tr> <tr><td><input type="checkbox"/></td><td>Hoses</td></tr> <tr><td><input type="checkbox"/></td><td>Connections (check for excessive wear, leaks and creep)</td></tr> </tbody> </table>	Verify	Check	<input type="checkbox"/>	Rams	<input type="checkbox"/>	Hoses	<input type="checkbox"/>	Connections (check for excessive wear, leaks and creep)																																																																																		
Verify	Check																																																																																									
<input type="checkbox"/>	Rams																																																																																									
<input type="checkbox"/>	Hoses																																																																																									
<input type="checkbox"/>	Connections (check for excessive wear, leaks and creep)																																																																																									
<p>Manildra use only</p> <p>NOTE: Sign only when all items have been checked</p> <p>Plant check by: _____</p> <p>Position: _____</p> <p>Date: _____ / ____ / ____</p>	<p style="text-align: center;">Note : Plant to be registered if used on public roads</p> <p>Instructions: Verify Box to be ticked by Owner / Supplier / Operator prior to arrival onsite. Check Box to be ticked after visual inspection by Manildra</p>																																																																																									